

INDEX

WHICHAIRDOYOU REQUIRE?.....3

Nylon coated steel telescopic slides

LST33RSERIES.....4

LST33RBS-RBDSERIES.....6

Aluminum telescopic rails with partial extraction

LNA34 SERIES.....8

LNA34RBASERIES.....10

Steel telescopic rails with partial extraction

LNL38SERIES.....12

Aluminum telescopic rails

LTA34SERIES.....14

LTA34RSERIES.....16

LTA34BTSERIES.....18

LTA51SERIES.....20

LTA51BS-BDSERIES.....22

LTA51ES-EDSERIES.....24

Steel telescopic rails

LTL45SERIES.....26

LTL56SERIES.....28

LTF68SERIES.....30

FIXINGMETHODS.....32

Howtocontactus.....33

MoreROLLONproductfamilies.....34



Which rail do you require?

In order to decide which LIGHT RAIL must be used, four main questions must be answered:

1) What load do you need to support?

ROLLON's LIGHT RAIL are capable of supporting loads from 30 kg to 250 kg. The graph shows the load capacity of a pair of fully extended rails.

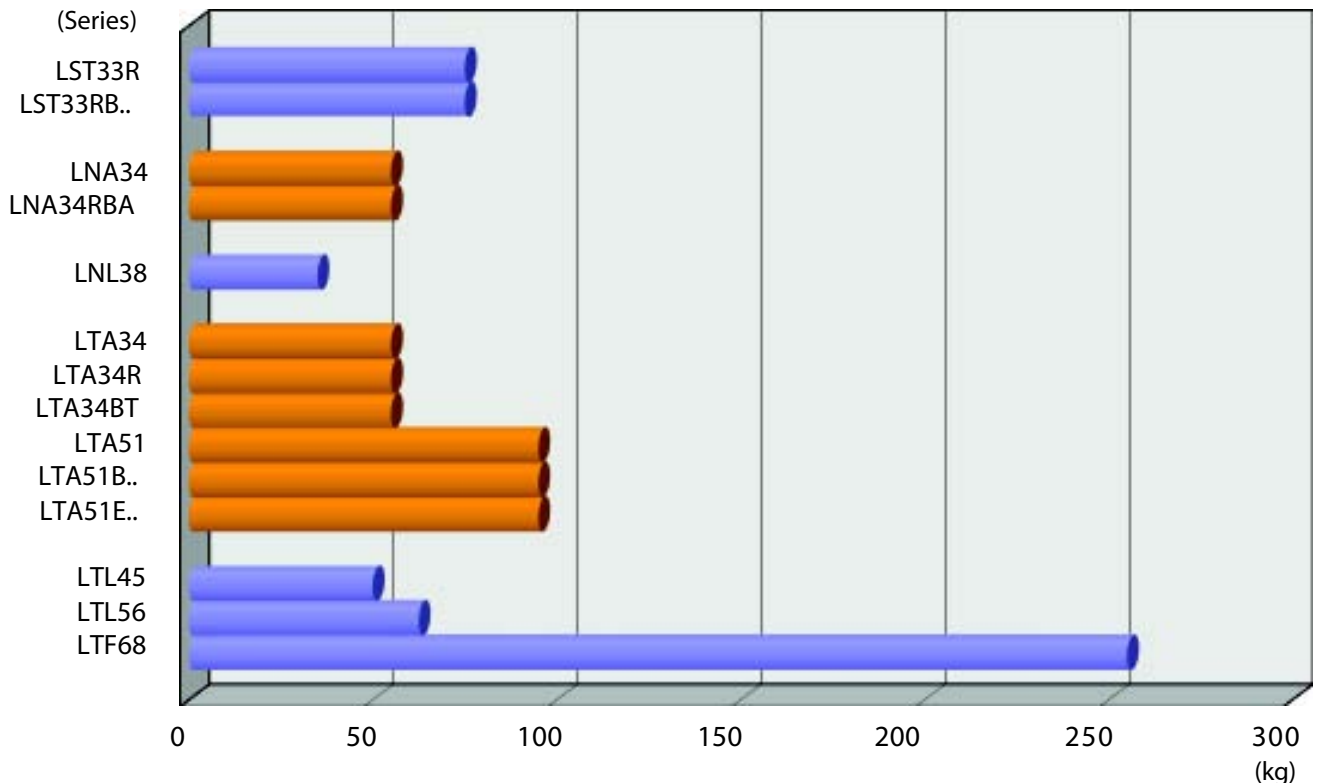

2) What closed length of rail can you accommodate?

The maximum closed length of a rail for any specific application is dictated by the depth of the cabinet into which the rail is to be installed.

3) What degree of extension is required?

Two beam rails will normally extend to between 50% and 75% of their closed length.

Three beam rails will extend to 100% or more.

Four beam rails will extend to 140%.

This means that the greater the degree of extension required for a given load, the heavier duty rail required.

4) What total profile is required?

The profile, or the amount of transversal space utilized, of a rail is another important factor to be considered in selecting the most appropriate rail for an application.

The LIGHT RAIL range of products offers various solutions to profile limitation problems.





NYLON COATED STEEL TELESCOPIC SLIDES LST33R Series

The LST 33R series telescopic slides are useful where space is limited but an easily removable chassis is wanted. They have a nylon coated center beam instead of a ball cage.

Turning a stud on the front stop 180° with a screwdriver releases the chassis. It can then be lifted out and a replacement fitted.

The LST33R series is particularly suited for applications involving shocks and vibrations. Austenitic stainless steel can be specified when a low - magnetic slide is required and for applications in the medical and food - preparation equipment.

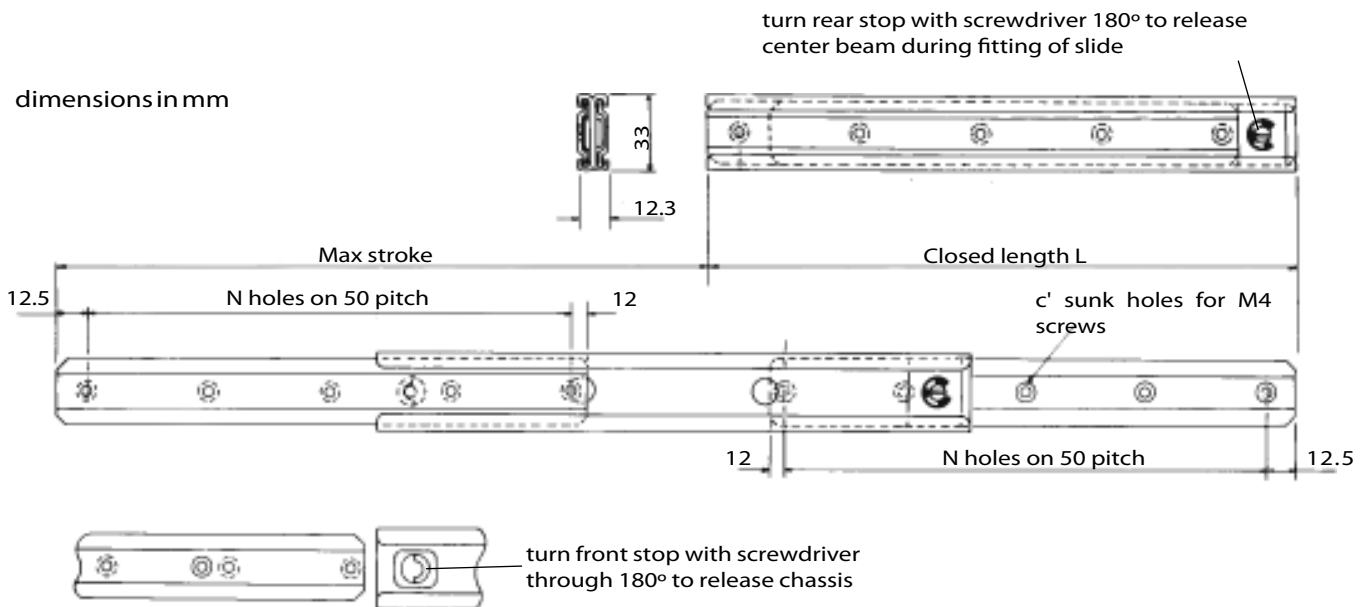

AVAILABILITY

Available in eight lengths as shown below.

All have strokes that are 25mm longer than closed length.

STANDARD LENGTHS - LST33R SERIES SLIDES

Closed length L (mm)	250	300	350	400	450	500	550	600
max stroke (mm)	275	325	375	425	475	525	575	625
No. of holes (in each beam)	5	6	7	8	9	10	11	12

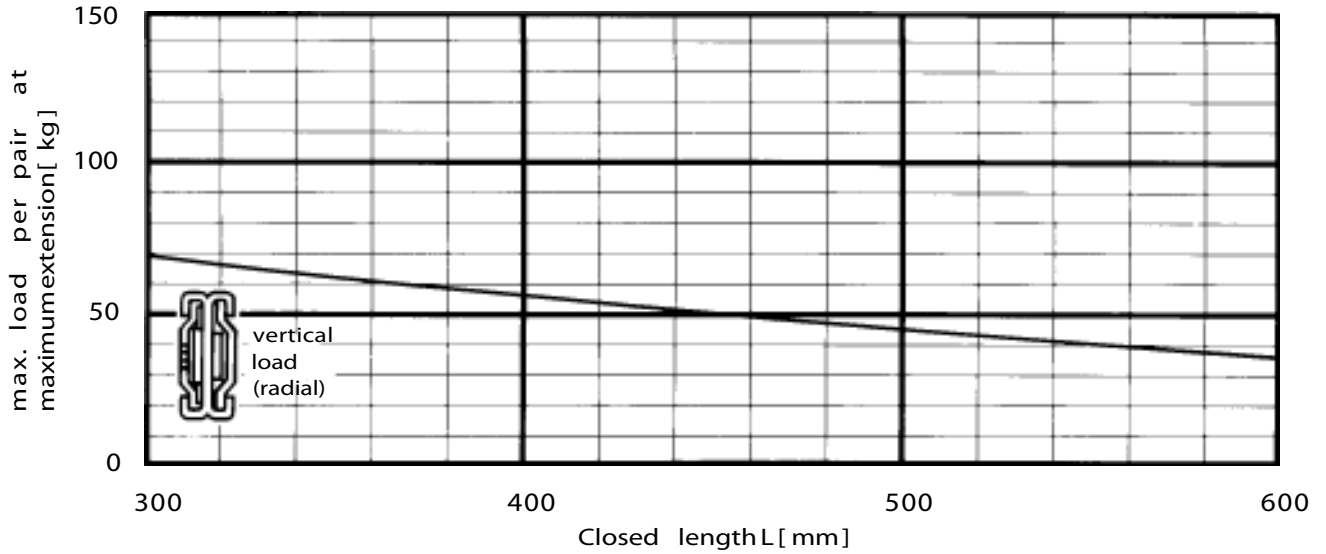

LOAD

This graph assumes a uniformly distributed load acting radially on a pair of slides which are rigidly attached to the structure throughout their length. Please consult our Technical Service when vibrations and shock conditions are involved.

SPECIFICATIONS

- All beams are made from steel.
- Inner beams are nylon coated.
- Outer beams are zinc plated including yellow passivation.
- Maximum operating temperature 70°C.
- Weight 1.8 kg/m per pair.

OPTIONS

LST33RBS, LST33RBD have trigger catch which locks slide when withdrawn and permits quick removal of chassis. See page 6.

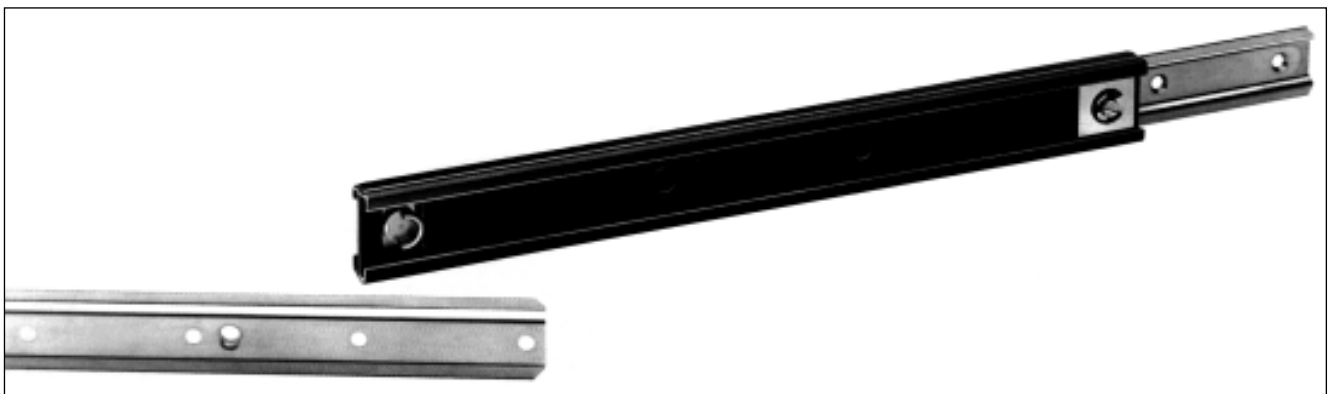

ORDER CODES

LST33R - 300

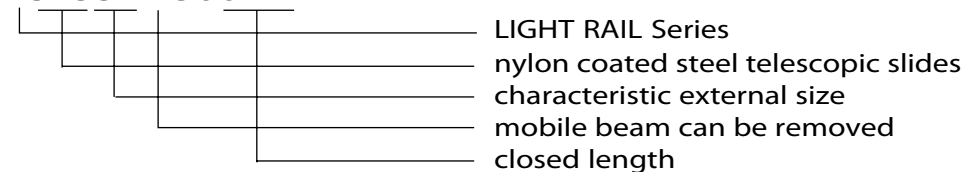



NYLON COATED STEEL TELESCOPIC SLIDES LST33RBS, LST33RBD Series

The LST33RBS, LST33RBD series telescopic slides are ideal for situations that require a compact slide which locks the chassis in the withdrawn position and allows it to be easily removed and replaced

The trigger mechanism automatically locks the slide when it is fully withdrawn. Gentle finger pressure on the front trigger releases the latch enabling the removal or closure of the slide. Approved for defense use. Not recommended for heavy chassis mounted on a sloping panel. This slide is particularly suited for applications involving shocks and vibrations. Austenitic stainless steel can be specified when a low - magnetic slide is required and for applications in the medical and food preparation equipment.

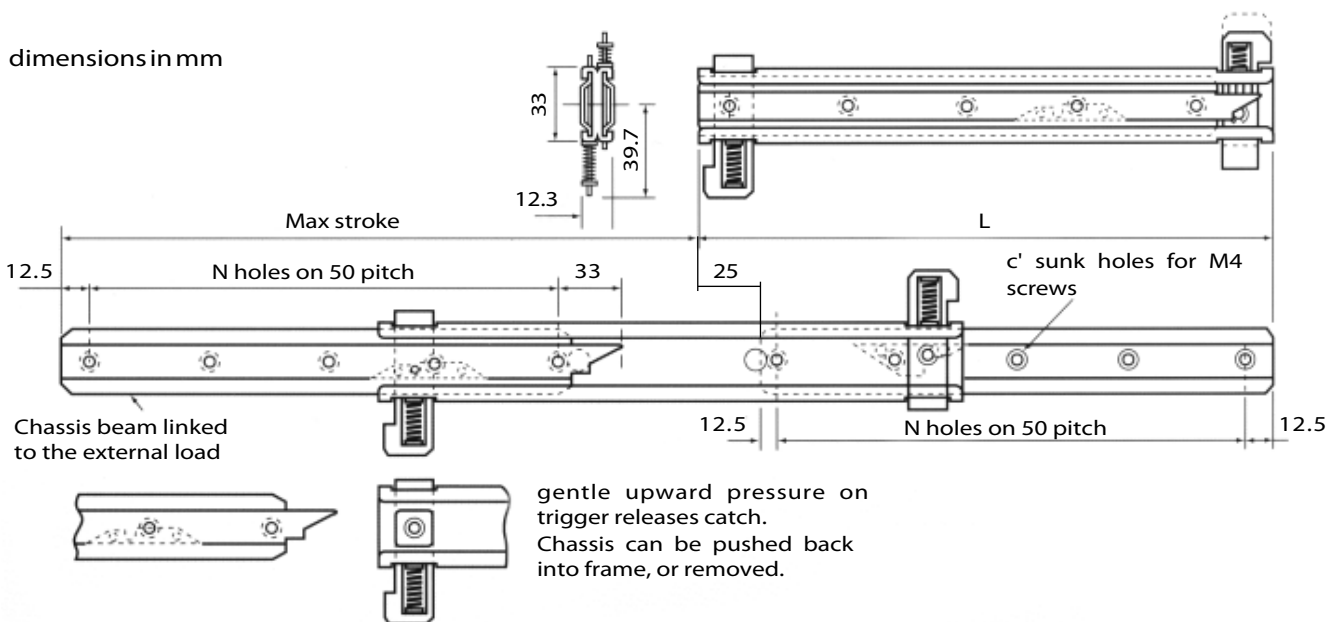

AVAILABILITY

Available in eight lengths as shown below.

All have strokes that are 25mm longer than closed length.

STANDARD LENGTHS - LST33RBS, LST33RBD SERIES SLIDES

Closed length L (mm)	250	300	350	400	450	500	550	600
max stroke (mm)	280	330	380	430	480	530	580	630
No. of holes (in each beam)	5	6	7	8	9	10	11	12

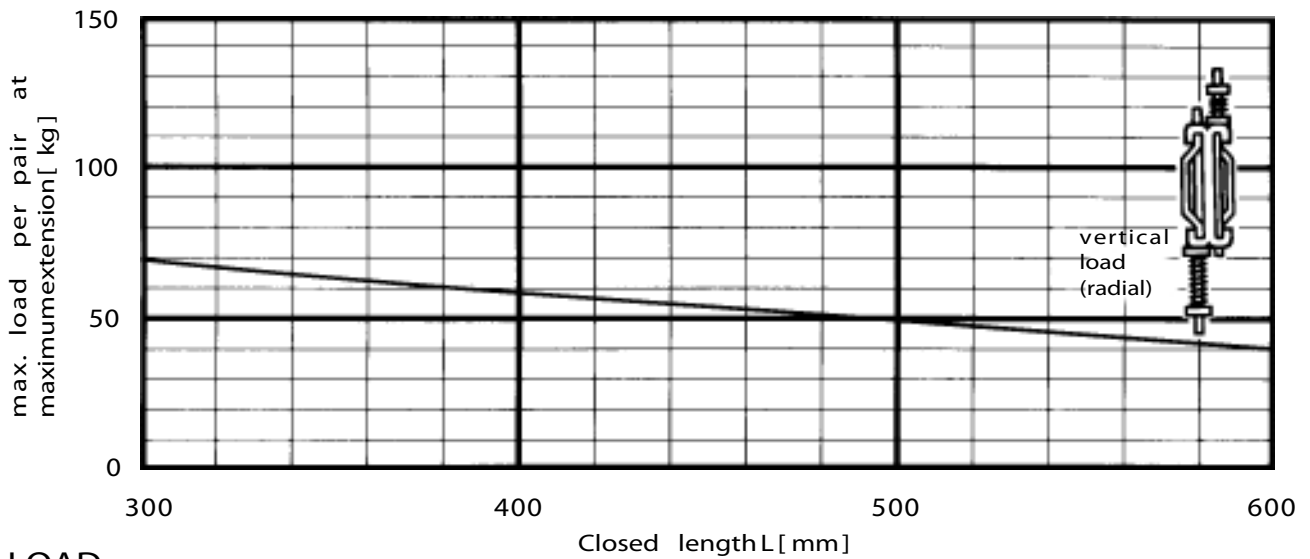

LOAD

This graph assumes a uniformly distributed load acting radially on a pair of slides which are rigidly attached throughout their length to the structure. Please consult our Technical Service when vibrations and shock conditions are involved.

SPECIFICATIONS

- All beams are made from steel.
- Inner beams are nylon coated.
- Outer beams are zinc plated including yellow passivation.
- Maximum operating temperature 70°C.
- Weight 1.8 kg/m per pair.

OPTIONS

In LST33R Series the mobile beam can be quickly removed. See page 4.



ORDER CODES

LST33RBS - 300

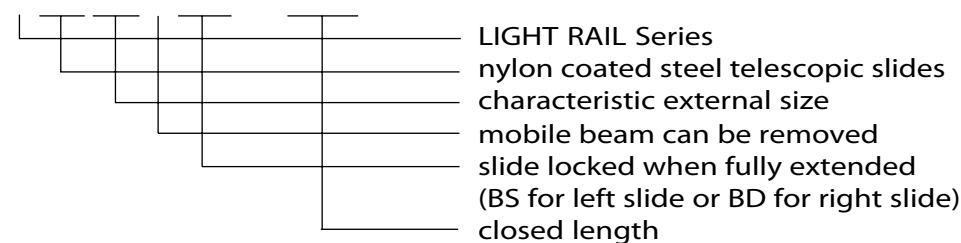



ALUMINUM TELESCOPIC RAILS WITH PARTIAL EXTRACTION LNA34 Series

The LNA34 series telescopic rails are extremely compact and are suitable for applications that do not require complete withdrawal.

The mechanical properties of both beams give the rail excellent load-carrying capabilities. Ball bearings, held in a steel cage, ensure smooth and easy operation. All of the slides listed below incorporate a single ball cage, giving the maximum practical extension for a two beam movement.

The stroke of this rail is determined by the length of the cage and not by the position of the end-stroke.

Dimensions in mm

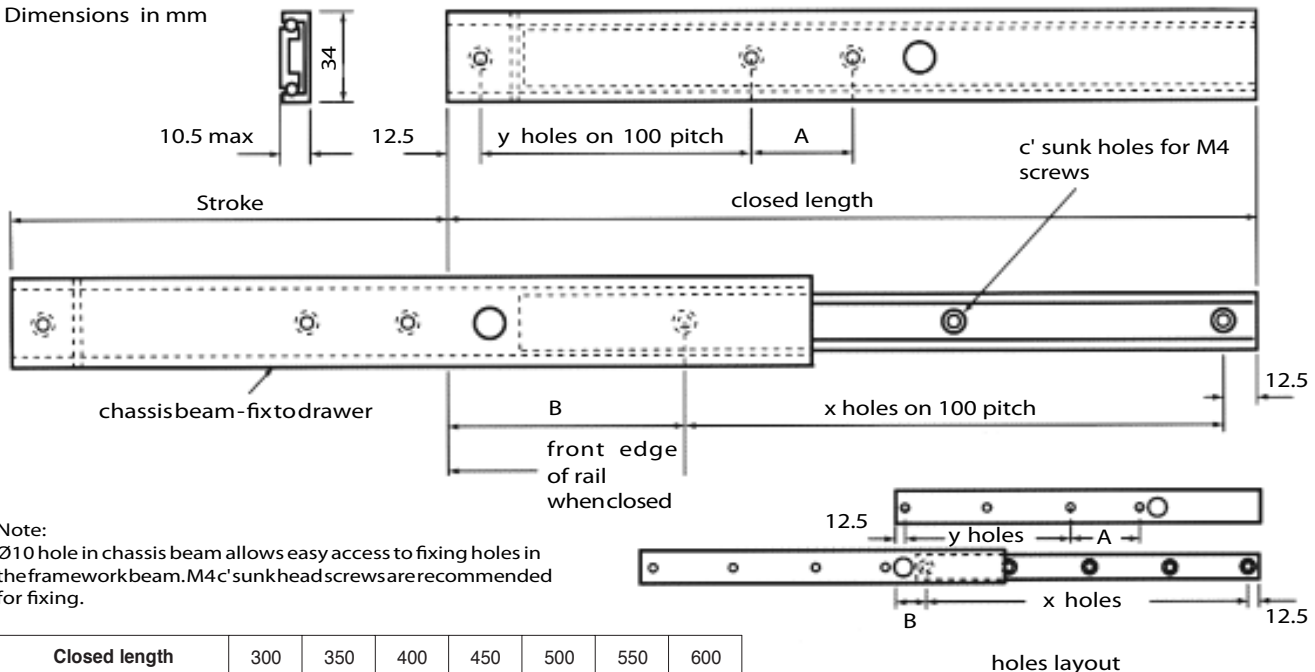

Note:
Ø10 hole in chassis beam allows easy access to fixing holes in the framework beam. M4 c' sunk head screws are recommended for fixing.

Closed length		300	350	400	450	500	550	600
stroke		165	215	265	315	340	390	440
chassis beam	tot. No. of fixing holes	3	3	4	4	5	5	6
	No. of holes on 100 pitch (y)	2	2	3	3	4	4	5
	dimension A	37.5	87.5	37.5	87.5	12.5	62.5	12.5
frame beam	No. of holes on 100 pitch (x)	3	4	4	5	5	6	6
	dimension B	87.5	37.5	87.5	37.5	87.5	37.5	87.5

AVAILABILITY

Available in seven lengths as shown below. Specialized individual requirements, such as additional cages to give more load capacity, can be evaluated.

STANDARD LENGTHS - LNA34 Series

Closed length in mm

300 350 400 450 500 550 600

Stroke in mm

165 215 265 315 340 390 440

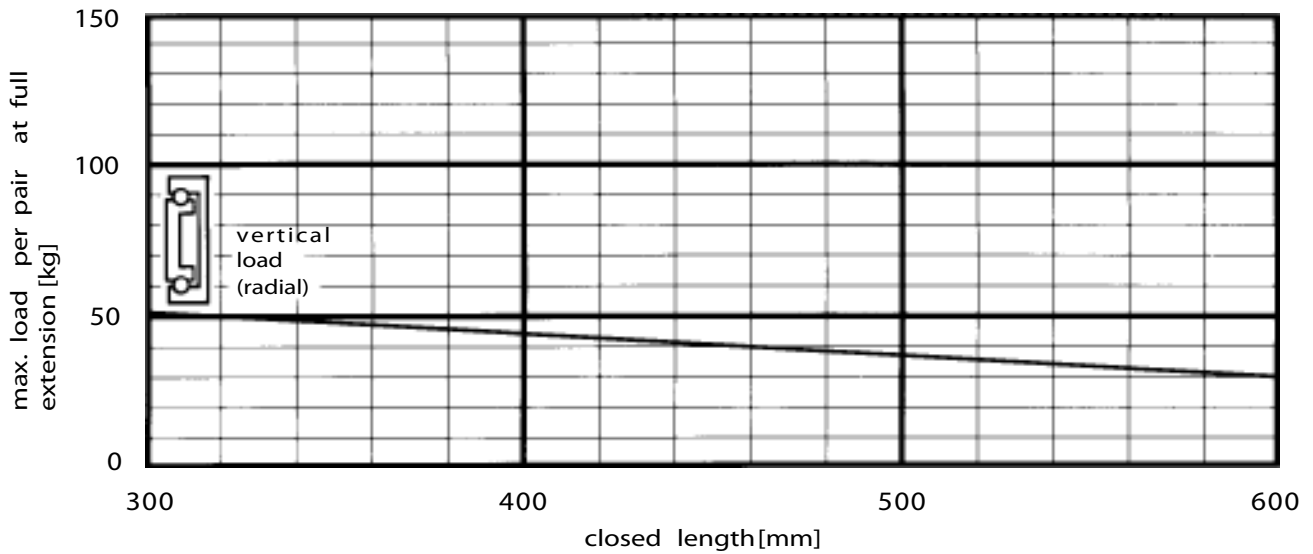

LOAD

This graph assumes a uniformly distributed load acting radially on a pair of slides which are rigidly attached throughout their length to the structure.

The loads indicated are based on a maximum slide deflection of 8 mm and a maximum opening force of 7 kg.

SPECIFICATIONS

All beams are made from anodized aluminum alloy

Ball bearings inside a steel ball cage allow the sliding movement.

Maximum operating temperature 70°C.

Weight 1.2 kg/m per pair.

OPTIONS

LNA34RBA allow a stroke equal to 75% of the length with lock out and removable chassis beam. See page 10.

LTA51 are similar and larger but offer complete telescopic movement (stroke longer than the length of the closed rail). See page 20.

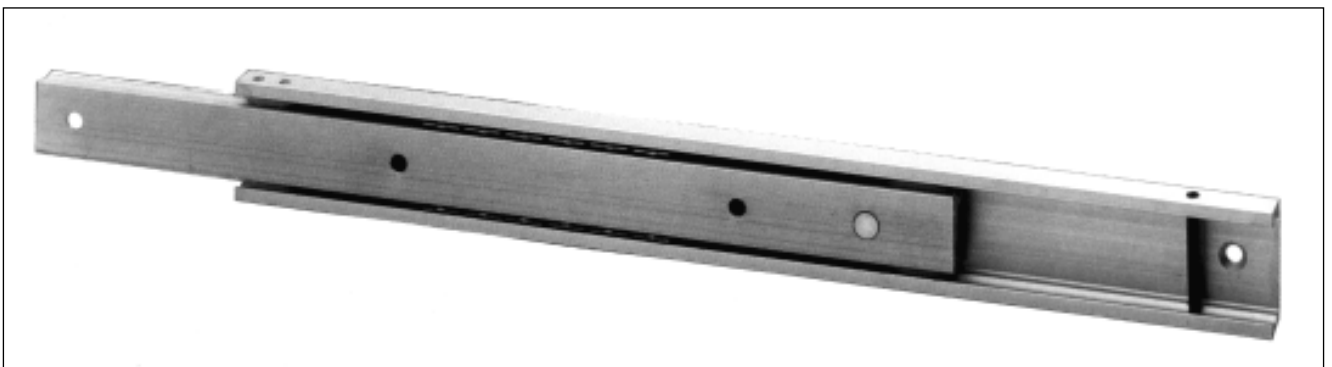

ORDER CODES

LNA34 - 300

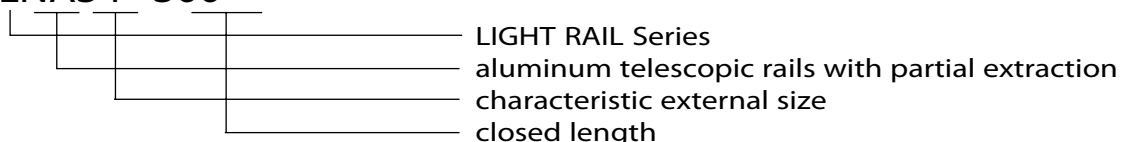



PACIFIC INTERNATIONAL BEARING SALES, INC.
800.228.8895 • WWW.PACIFICBEARINGSALES.COM

ALUMINUM TELESCOPIC RAILS WITH PARTIAL EXTRACTION LNA34RBA Series

The LNA34RBA series telescopic rails are extremely compact with 75% extension. They incorporate a latch which automatically locks the slide when fully extended. Gentle finger pressure on the exposed spring releases the latch, enabling the chassis beam to either be closed or removed. Re-insertion is assisted by the tapered end of the chassis beam and nylon guides in the framework. These also stabilize the chassis when closed. The mechanical properties of both beams give the rail excellent load-carrying capabilities. Ball bearings, held in a steel cage, ensure smooth and easy operation.

Dimensions in mm

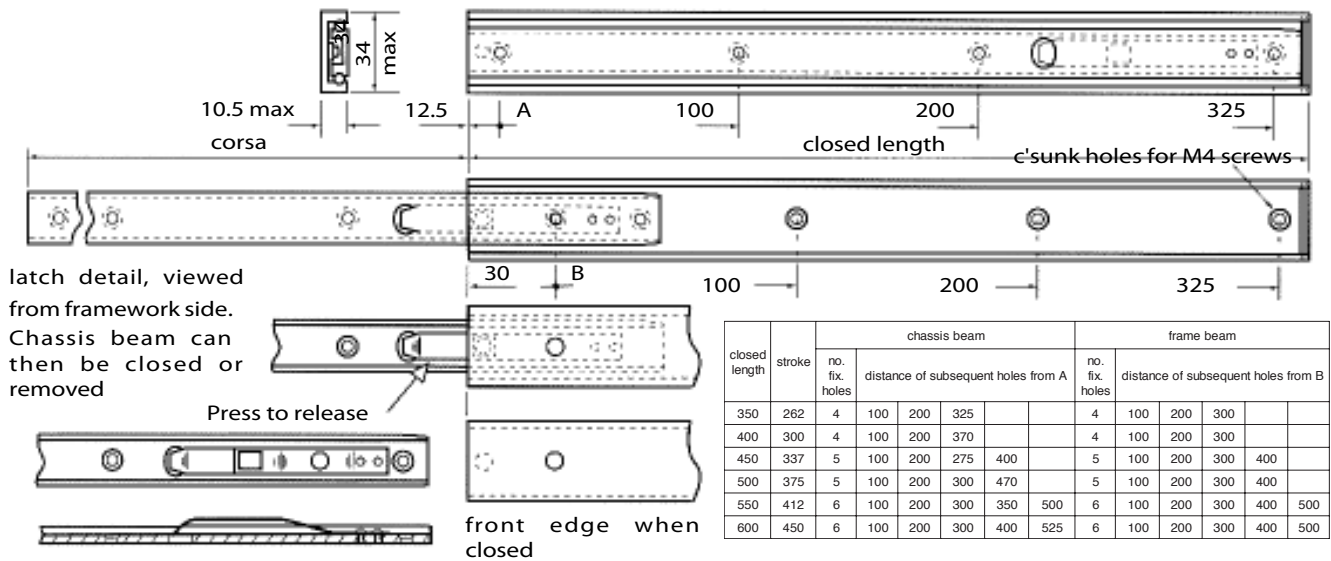

AVAILABILITY

Available in six lengths as shown below. Specialized individual requirements, such as additional cages to give more load capacity with reduced extension, can be evaluated.

STANDARD LENGTHS - LNA34RBA Series

Closed length (in mm)

350 400 450 500 550 600

Stroke (in mm)

262 300 337 375 412 450

LATCHING

The latch is intended for horizontal use under static conditions only. To allow access for release, the front edge of the rail must be in line, or set back a maximum of 5 mm, with the front edge of the cabinet.

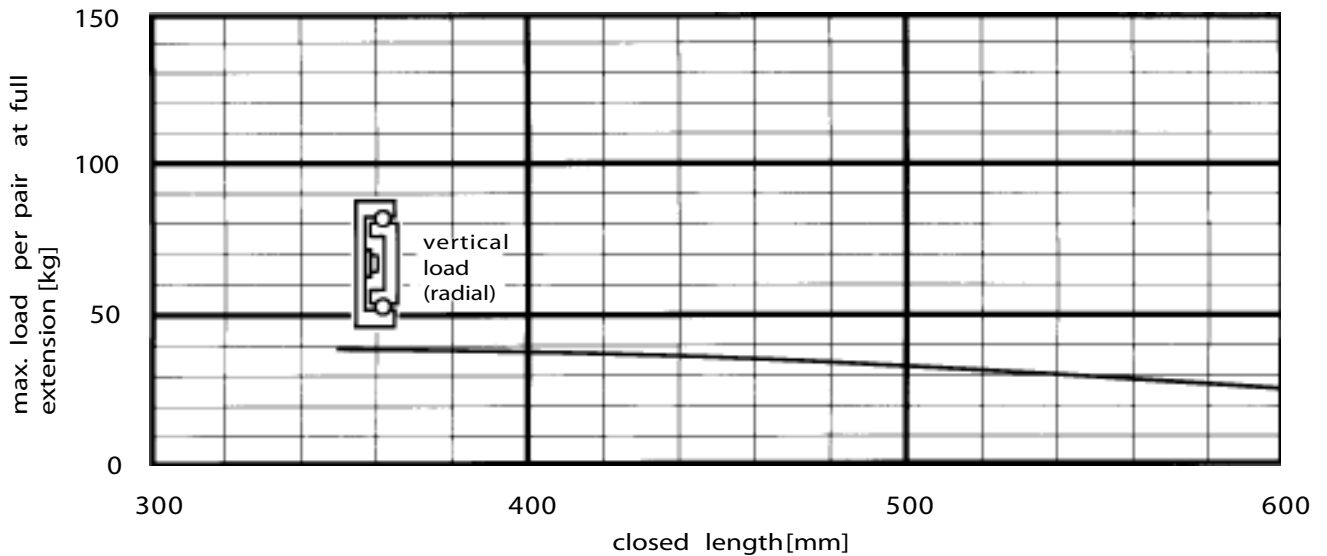

LOAD

This graph assumes a uniformly distributed load acting radially on a pair of slides which are rigidly attached throughout their length to the structure. The loads indicated are based on a maximum slide deflection of 4.5 mm and a maximum opening force of 7 kg.

SPECIFICATIONS

- All beams are made from anodized aluminum alloy
- Ball bearings inside a steel ball cage allow the sliding movement.
- Maximum operating temperature 70°C.
- Weight 1.2 kg/m per pair.

OPTIONS

LNA34 similar but without latch and with maximum stroke equal to 50% of closed length. See page 8.

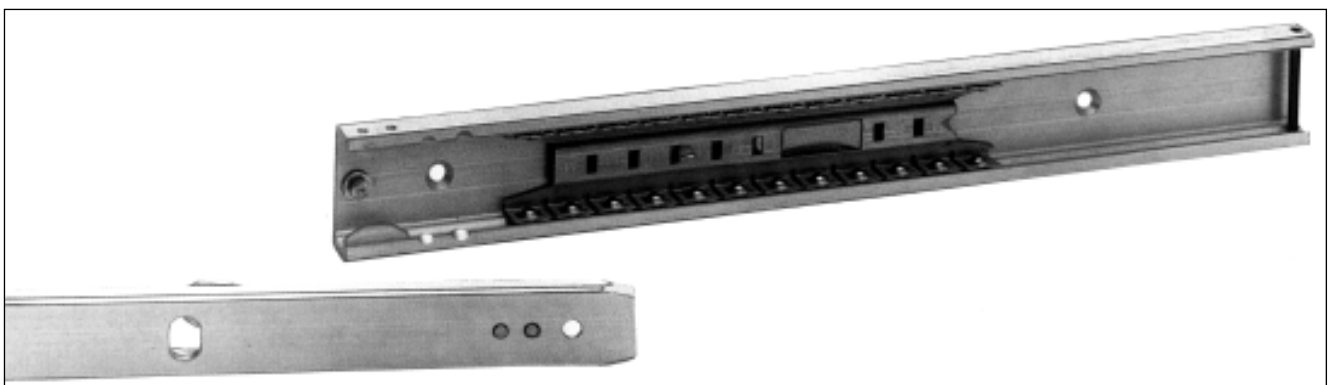

ORDER CODES

LNA34RBA - 350

- LIGHT RAIL Series
- aluminum telescopic rails with partial extraction
- characteristic external size
- mobile beam can be removed
- rail locked when fully extended
- closed length



STEEL TELESCOPIC RAILS WITH PARTIAL EXTRACTION

LNL38 Series

LNL38 slides are a new entry in LIGHTRAIL family products. They are made with a mobile and a fixed element, both in folded sheet metal. Advantages are the extremely low weight with a good load capacity and the low room section.

Dimensions in mm

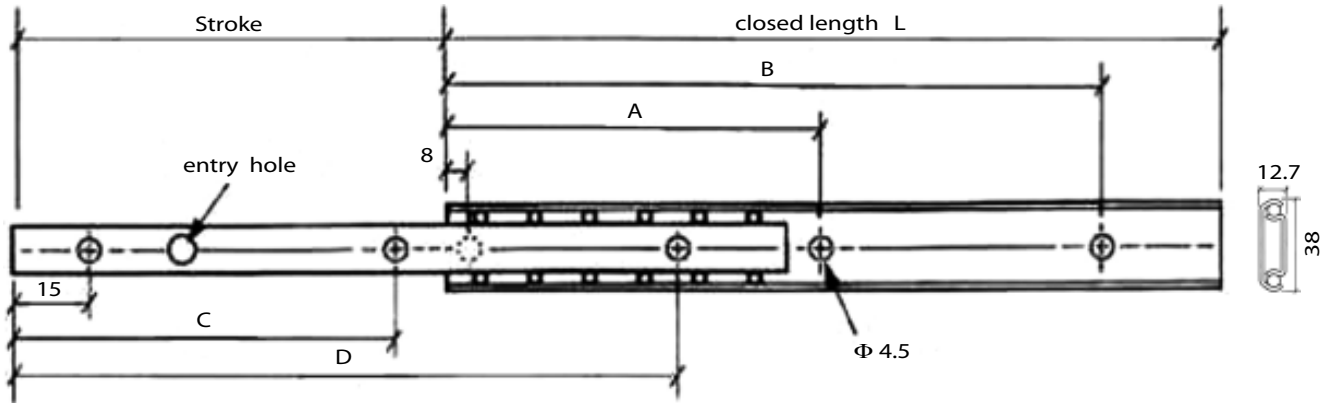

Closed length L (mm)	Stroke (mm)	A (mm)	B (mm)	C (mm)	D (mm)
300	213	136	264	111	175
350	263	136	296	111	239
400	313	168	360	143	271
450	365	200	392	143	303
500	392	232	456	175	367
550	416	264	520	175	367
600	465	264	552	207	399
650	493	296	616	239	463
700	515	328	648	239	463

AVAILABILITY

Available in nine lengths as shown below, from 300 to 700 mm, with strokes from 213 to 515 mm.

STANDARD LENGTHS - LNL38 Series

Please consult the table above.

**LOAD**

Capacity load: 30 kg

This load must be read as a uniformly distributed load acting radially on a pair of slides 400 mm length which are rigidly attached throughout their length to the structure and to the moving part.

SPECIFICATIONS

All beams are made from zinc plated steel.

Ball bearings allow the sliding movement.

Weight: 2,6 kg/m per pair.

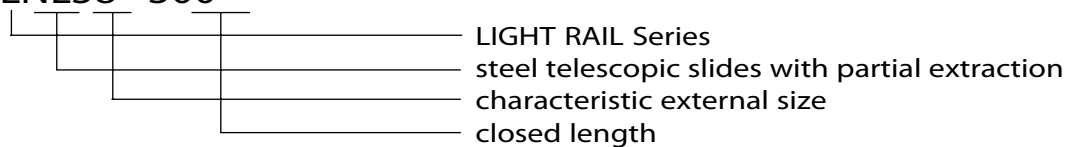
**ORDER CODES****LNL38 - 300**



ALUMINUM TELESCOPIC RAILS LTA34 Series

The LTA34 telescopic series are small aluminum alloy, three-beam ball bearing rails. The “I” shaped chassis holds the two “C” shaped beams. The mechanical properties of both beams give the rail excellent load-carrying capabilities. Ball bearings, held in steel cages, ensure smooth and easy operation.

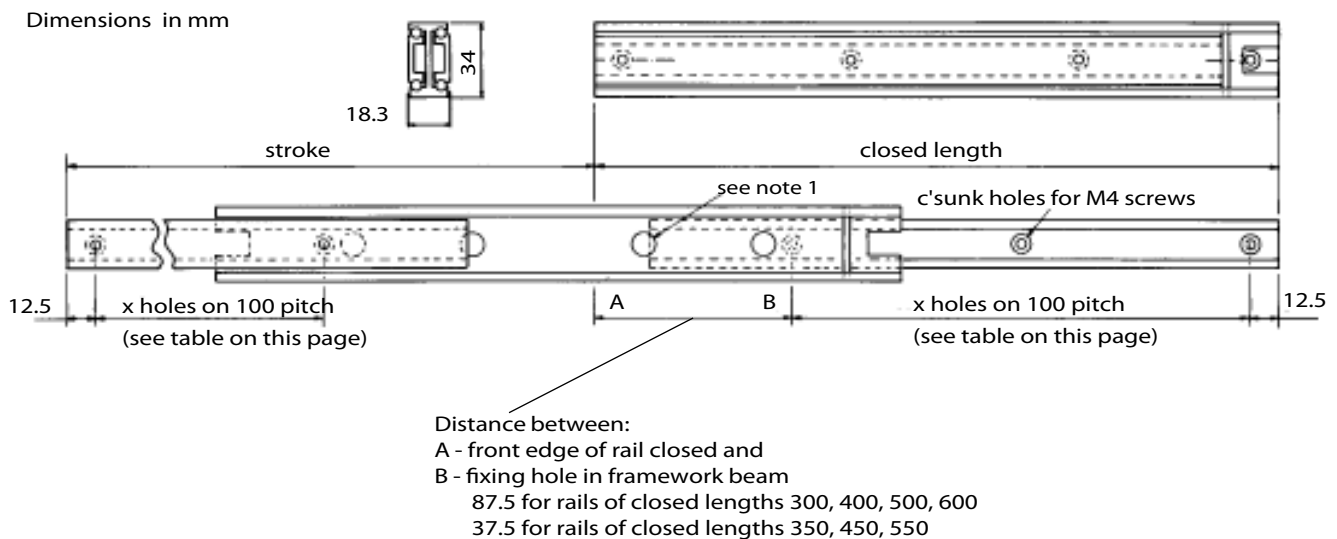

note 1: Ø10 mm holes in center beam allow easy access to fixing holes.

AVAILABILITY

Available in seven lengths as shown below. All incorporate 30 mm over-extension, thus effectively covering depths from around 300 mm to 630 mm.

STANDARD LENGTHS - LTA34 Series

Closed length (in mm)

300 350 400 450 500 550 600

Stroke (in mm)

330 380 430 480 530 580 630

No. of holes in each beam (x)

3 4 4 5 5 6 6

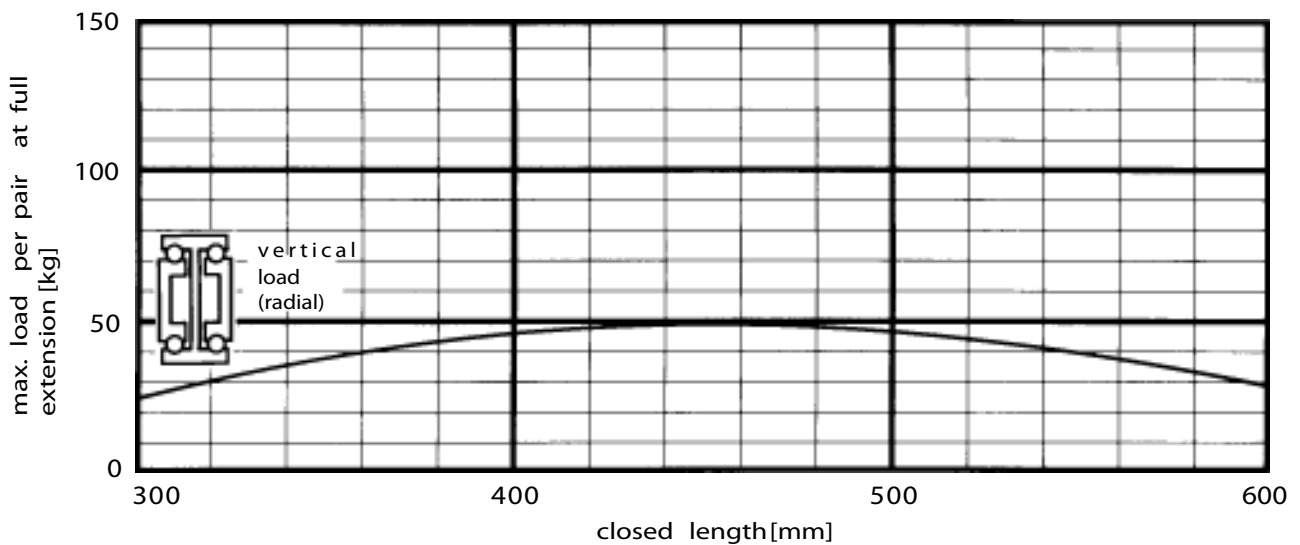

LOAD

This graph assumes a uniformly distributed load acting radially on a pair of rails which are rigidly attached throughout their length to the structure. The maximum load is governed by both the sag of the extended rail and the strength of the other rails components. The result is a rail whose load capacity increases with lengths up to 450 mm, after which the inverse ratio applies. The loads indicated are based on a maximum rail deflection of 8 mm and a maximum opening force of 7 kg.

SPECIFICATIONS

- All beams are made from anodized aluminum alloy
- Ball bearings inside steel cages allow the sliding movement.
- Maximum operating temperature 70° C.
- Weight 2 kg/m per pair.

OPTIONS

- LTA34R are similar but incorporate a spring stop that allows the beam to be removed. See page 16.
- LTA34BT are similar but incorporate a system that locks the rail open or closed. See page 18.
- LTA51.. are larger and offer complete telescopic movement (Stroke longer than the length of the closed rail). See pages 20-22-24.

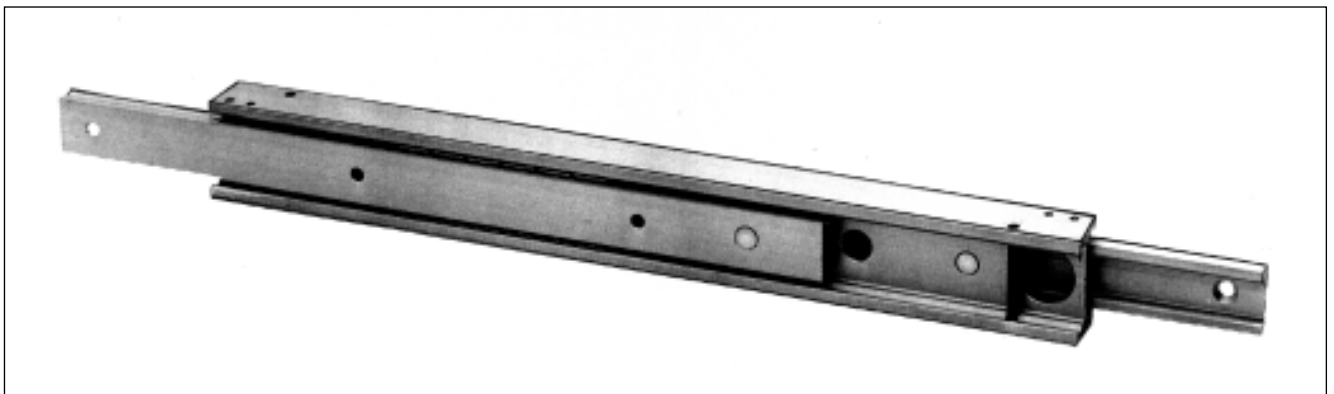

ORDER CODES

LTA34 - 300

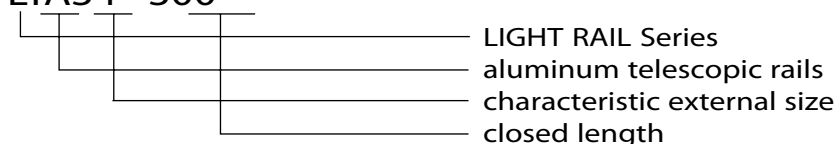



ALUMINUM TELESCOPIC RAILS

LTA34R Series

The LTA34R series telescopic are small aluminum alloy three-beam ball bearing rails. The chassis is easily removable. The mechanical properties of both beams give the rail excellent load-carrying capabilities.

Ball bearings, held in a steel cage, ensure smooth and easy operation.

Simple depression of the front catch releases the chassis beam enabling removal.

Dimensions in mm

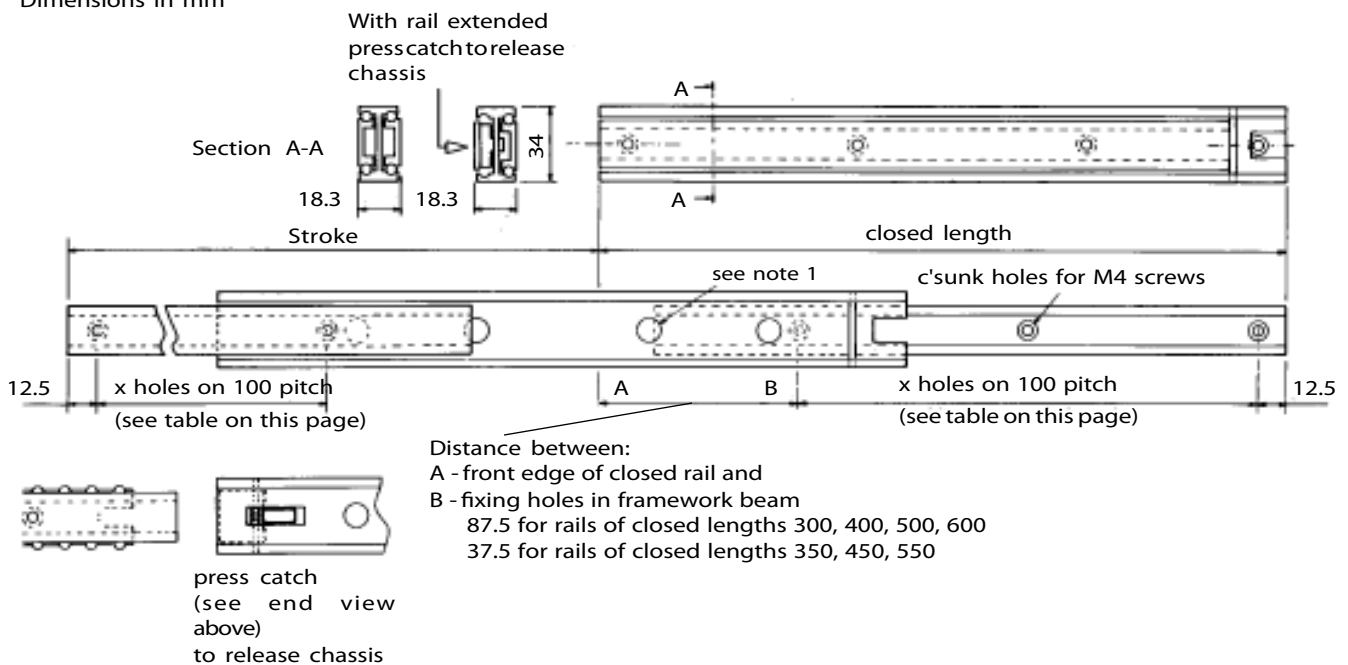

note 1: \varnothing 10 mm holes in center beam allow easy access to fixing holes.

AVAILABILITY

Available in seven lengths as shown below. All incorporate 30 mm over-extension, thus effectively covering depths from around 300 mm to 630 mm.

Special requests can be discussed with our Technical Department.

STANDARD LENGTHS - LTA34R Series

Closed length in mm

300 350 400 450 500 550 600

Stroke in mm

330 380 430 480 530 580 630

No. of holes in each beam (x)

3 4 4 5 5 6 6

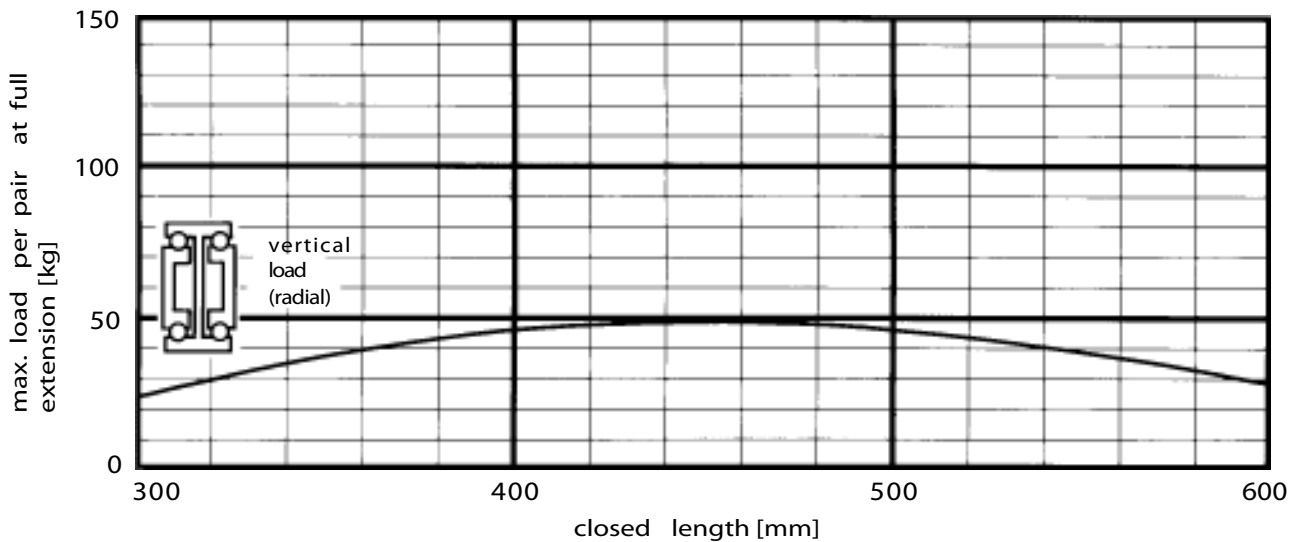

LOAD

This graph assumes a uniformly distributed load acting radially on a pair of rails which are rigidly attached throughout their length to the structure. The maximum load is governed by both the sag of the extended rail and the strength of the other rail components. The result is a rail whose load capacity increases with lengths up to 450mm, after which the inverse ratio applies. The loads indicated are based on a maximum rail deflection of 8mm and a maximum opening force of 7 kg.

SPECIFICATIONS

- All beams are made from anodized aluminum alloy.
- Ball bearings inside steel cages allow the sliding movement.
- Maximum operating temperature 70°C.
- Weight 2 kg/m per pair.

OPTIONS

- LTA34 are similar but do not incorporate the spring stop that allows the beam to be removed. See page 14.
- LTA34BT are similar but incorporate a system that locks the rail open or closed. See page 18.
- LNA34.. is a two beam version. See pages 8-10.
- LTA51.. are larger and offer complete telescopic movement (Stroke longer than the length of the closed rail). See pages 20-22-24.



ORDER CODES

LTA34R - 300

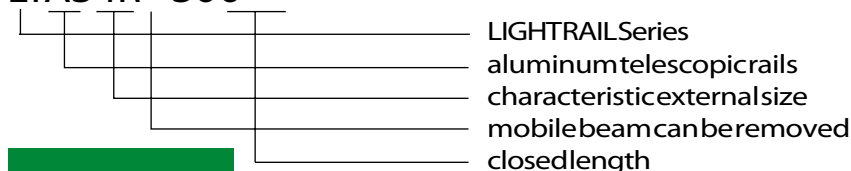



ALUMINUM TELESCOPIC RAILS

LTA34BT Series

The LTA34BT series telescopic are small, aluminum alloy, three-beam ball bearing rails. In addition to other outstanding features it has an integral latching system which locks the rails when fully extended and retains it when fully closed. A firm initial pull is all that is necessary to open it, after which the rail travels freely. The rail is symmetrical.

The photograph shows the framework side in order to show the latch, which is pressed downward to release.

The mechanical properties of both beams give the rail excellent load-carrying capabilities. Ball bearings, held in steel cages, ensure smooth and easy operation.

Dimensions in mm

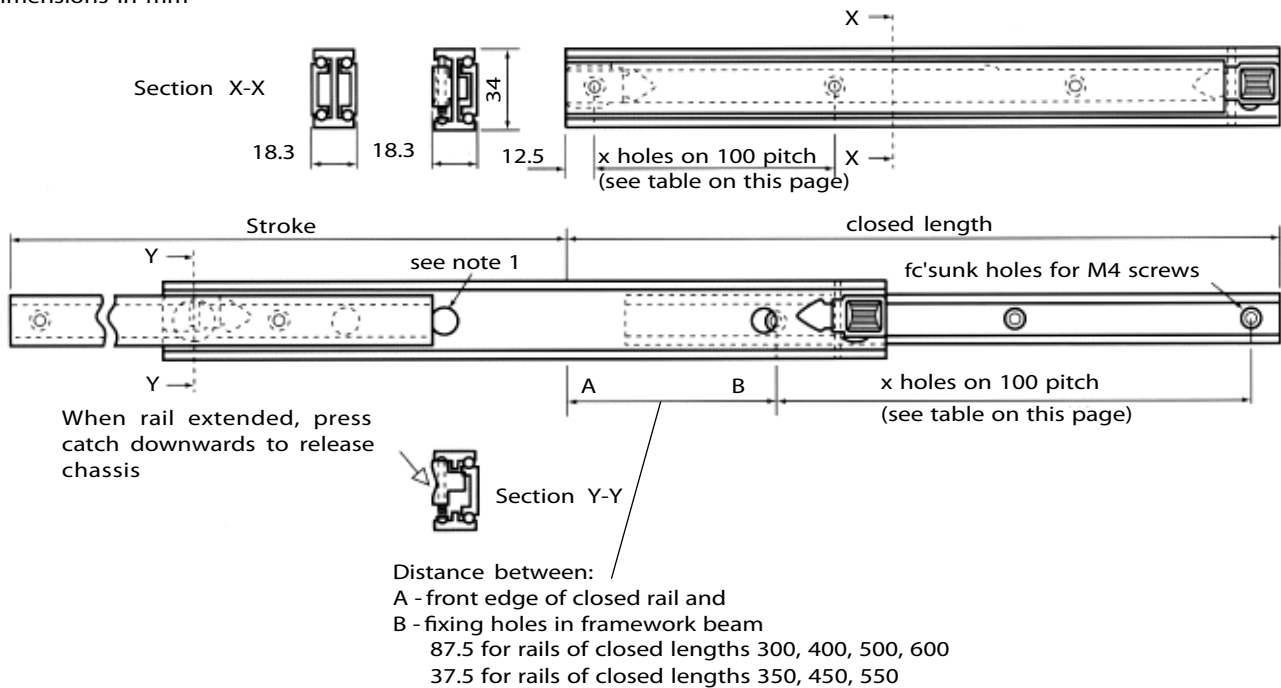

note 1 : \varnothing 10mm holes in center beam allow easy access to fixing holes.

AVAILABILITY

Available in seven lengths as shown below. All incorporate 30 mm over-extension, thus effectively covering depths from around 300mm to 630mm.

Special requests can be discussed with our Technical Department.

STANDARD LENGTHS-LTA34BT Series

Closed length in mm

300 350 400 450 500 550 600

Stroke in mm

330 380 430 480 530 580 630

No. of holes in each beam (x)

3 4 4 5 5 6 6

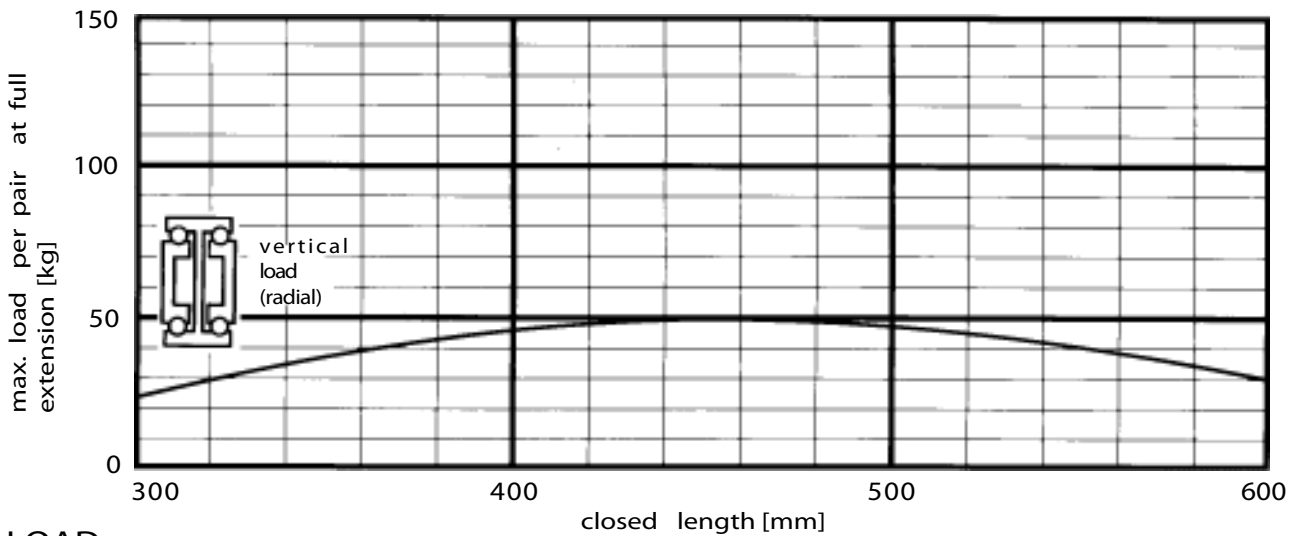

LOAD

This graph assumes a uniformly distributed load acting radially on a pair of rails which are rigidly attached throughout their length to the structure. The maximum load is governed by both the sag of the extended rail and the strength of the other rail components. The result is a rail whose load capacity increases with lengths up to 450mm, after which the inverse ratio applies. The loads indicated are based on a maximum rail deflection of 8mm and a maximum opening force of 7 kg.

SPECIFICATIONS

- All beams are made from anodized aluminum alloy.
- Ball bearings inside steel cages allow the sliding movement.
- Maximum operating temperature 70°C.
- Weight 2 kg/m per pair.

OPTIONS

- LTA34 are similar but do not incorporate the spring stop that allows the beam to be removed. See page 14.
- LTA34R are similar but incorporate a spring stop that allows the beam to be removed. See page 16.
- LTA51 are larger and offer complete telescopic movement (Stroke longer than the length of the closed rail). See pages 20-22-24.



ORDER CODES

LTA34BT - 300

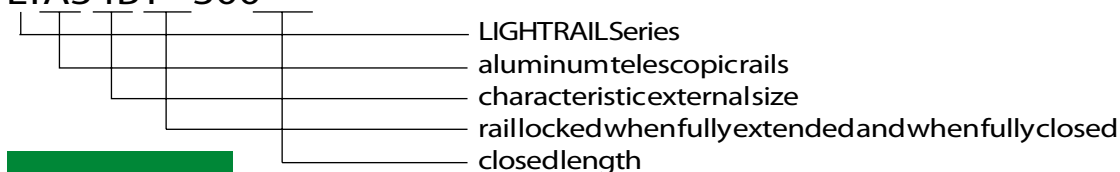



ALUMINUM TELESCOPIC RAILS

LTA51 Series

The LTA51 are small aluminum alloy telescopic rails with smooth movement and low pull-out force coupled with good load carrying capacity. The design is symmetrical with the metal largely equalized between the beams.

Wide outer beams result in a high load carrying ability and reduce deflection.

A row of ball bearings concealed in nylon cages ensures smooth and easy operation.

Dimensions in mm

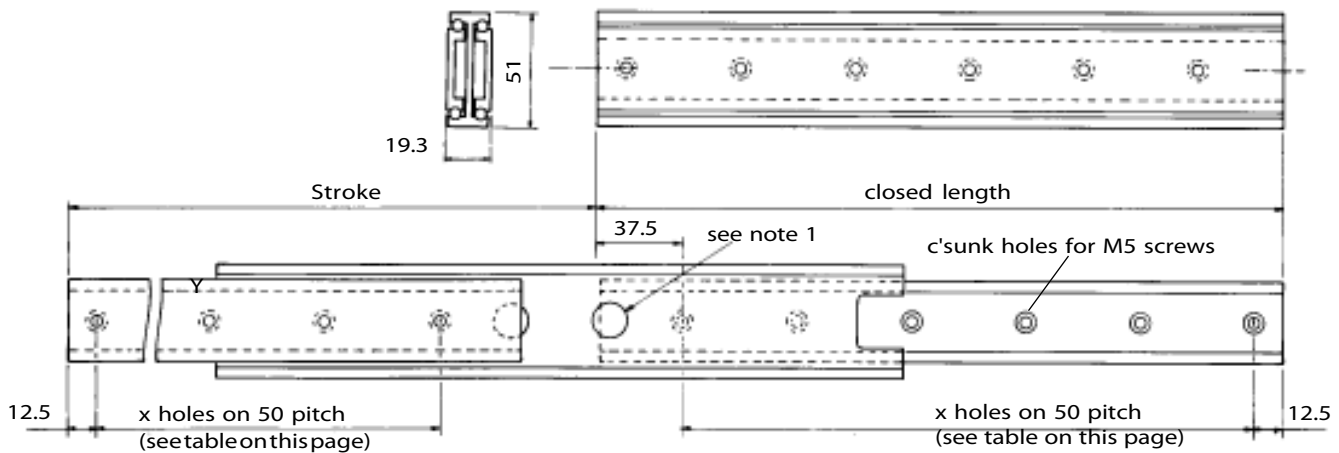

note 1: $\varnothing 15$ mm holes in center beam allow easy access to fixing holes.

AVAILABILITY

Available in seven lengths as shown below. All incorporate 30 mm over-extension, thus effectively covering depths from around 300 mm to 630 mm.

Special requests can be discussed with our Technical Department.

STANDARD LENGTHS - LTA51 Series

Closed length in mm

300 350 400 450 500 550 600

Stroke in mm

330 380 430 480 530 580 630

No. of holes in each beam (x)

6 7 8 9 10 11 12

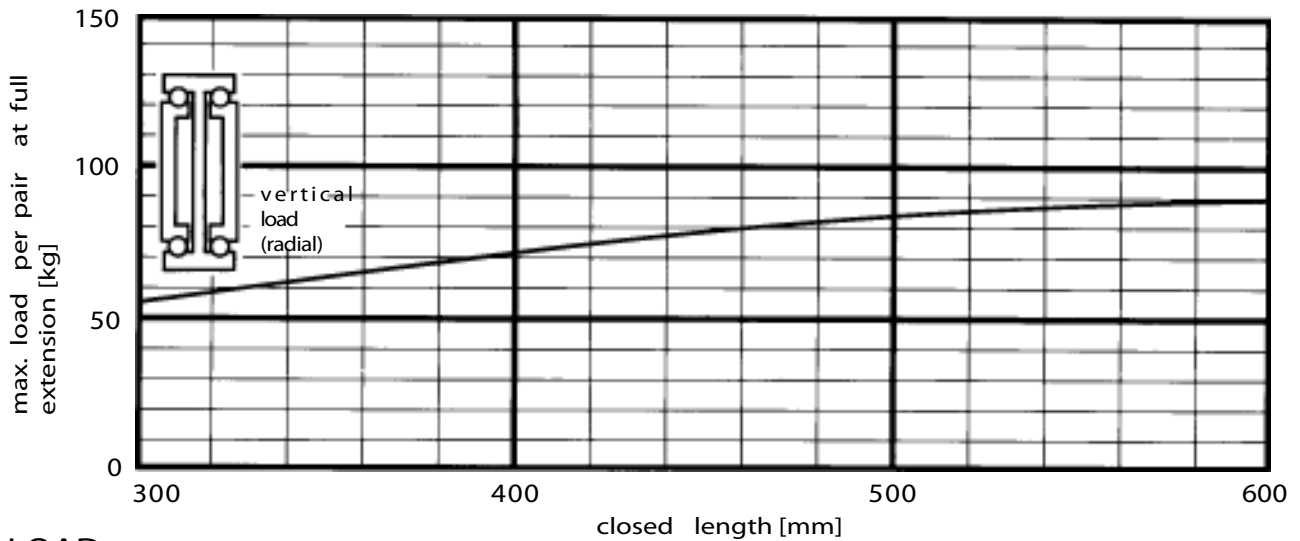

LOAD

This graph assumes a uniformly distributed load acting radially on a pair of rails which are rigidly attached throughout their length to the structure. The maximum load is governed by both the sag of the extended rail and the strength of the other rail components. The result is a slide whose load capacity increases with length over the standard range. The loads indicated are based on a maximum rail deflection of 7 mm and a maximum opening force of 8 kg.

SPECIFICATIONS

- All beams are made from anodized aluminum alloy.
- Ball bearings inside nylon cages allow the sliding movement.
- Maximum operating temperature 70°C.
- Weight 3.4 kg/m per pair.

OPTIONS

- LTA51BS and LTA51BD are similar but incorporate a built in latch, operating when the rail is fully closed or fully extended. See page 22.
- LTA51ES and LTA51ED are similar but incorporate a built in latch, operating when the rail is fully extended only. See page 24.
- LTA34.. are a smaller version. See pages 14-16-18.

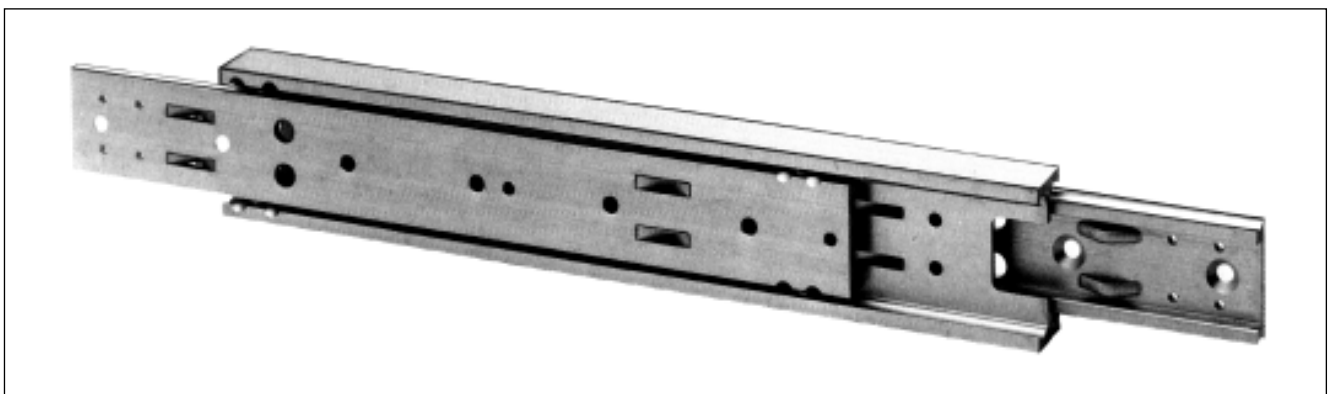

ORDER CODES

LTA51 - 300

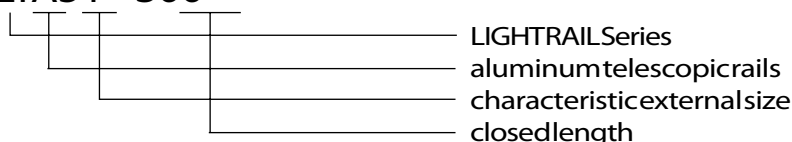



ALUMINUM TELESCOPIC RAILS LTA51BS, LTA51BD Series

The LTA51BS and LTA51BD are a pair of ball bearing rails with a complete integrallatching system.

The photograph shows the latching lever which automatically engages in studs both when the rail is fully extended and when fully closed. In the presence of a front panel, space must be made for the projecting lever in the panel itself. The design is symmetrical and the central “I” shaped beam gives the slide excellent load carrying ability.

A row of ball bearings concealed in nylon cages ensures smooth and easy operation.

Dimensions in mm

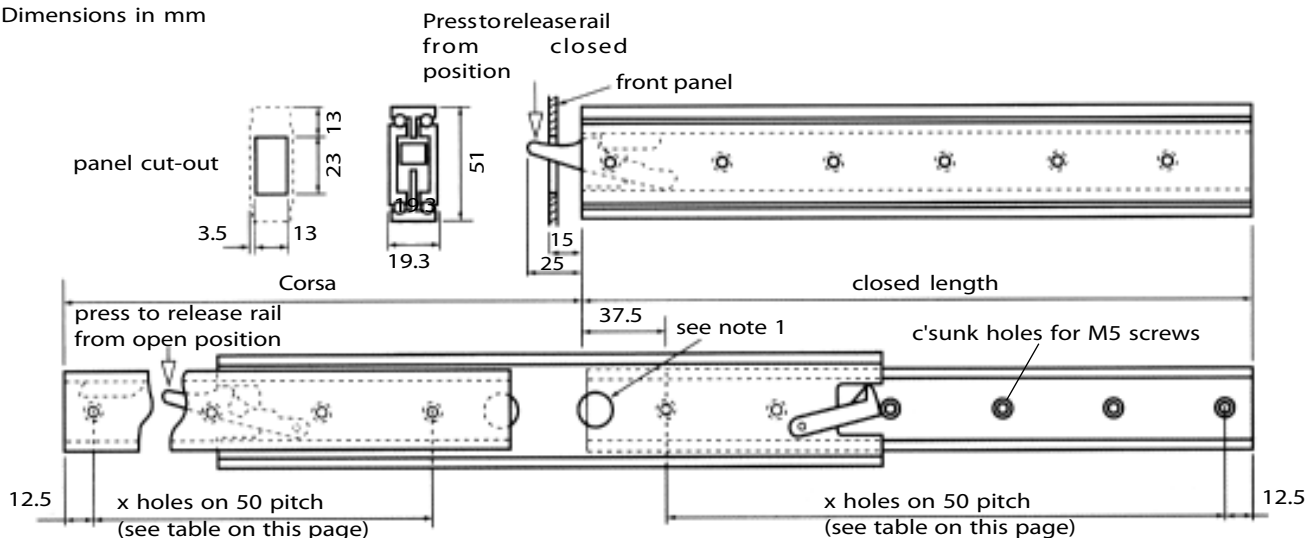

note 1: \varnothing 15 mm holes in center beam allow easy access to fixing holes.

AVAILABILITY

Available in seven lengths as shown below. All incorporate 30 mm over-extension, thus effectively covering depths from around 300mm to 630mm.

Special requests can be discussed with our Technical Department.

STANDARD LENGTHS - LTA51BS, LTA51BD Series

Closed length in mm

300 350 400 450 500 550 600

Stroke in mm

330 380 430 480 530 580 630

No. of holes in each beam (x)

6 7 8 9 10 11 12

Cabinet depth must allow for latch space.

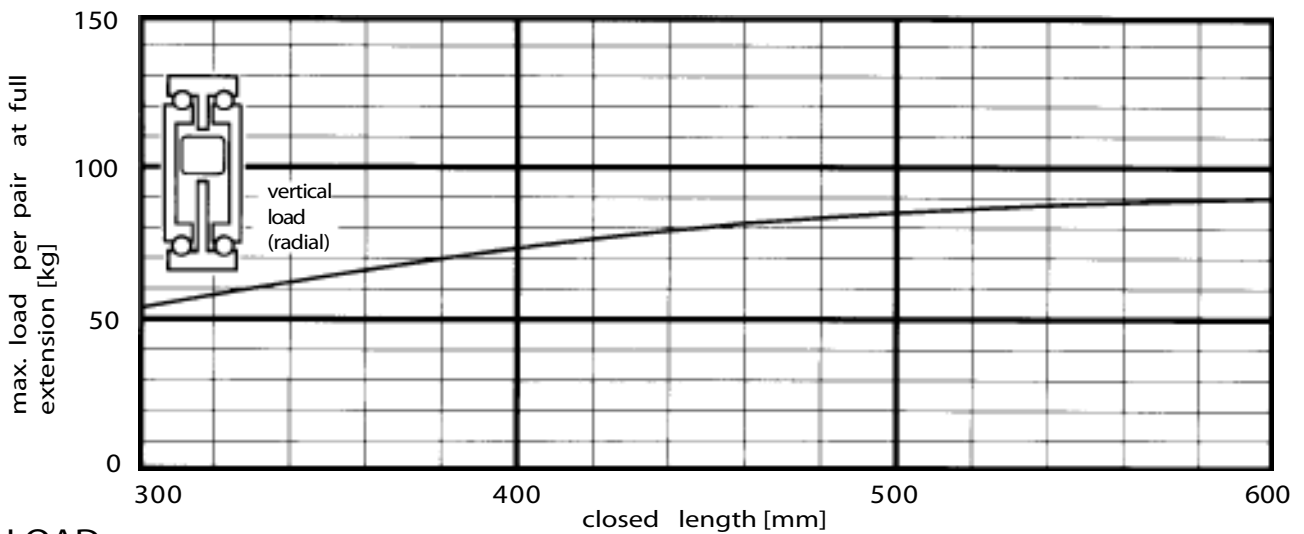

LOAD

This graph assumes a uniformly distributed load acting radially on a pair of rails which are rigidly attached throughout their length to the structure. The maximum load is governed by both the sag of the extended rail and the strength of the other rail components. The result is a slide whose load capacity increases with length over the standard range. The loads indicated are based on a maximum rail deflection of 7 mm and a maximum opening force of 8 kg.

SPECIFICATIONS

- All beams are made from anodized aluminum alloy
- Latch components diecast in zinc alloy
- Ball bearings in nylon cages allow the sliding movement.
- Maximum operating temperature 70°C.
- Weight 3.4 kg/m per pair.

OPTIONS

- LTA51 are similar but do not incorporate a built in latch. See page 20.
- LTA51ES and LTA51ED are similar but incorporate a built in latch which operates when the slide is fully extended. See page 24.
- LTA34.. are a smaller version. See pages 14-16-18.

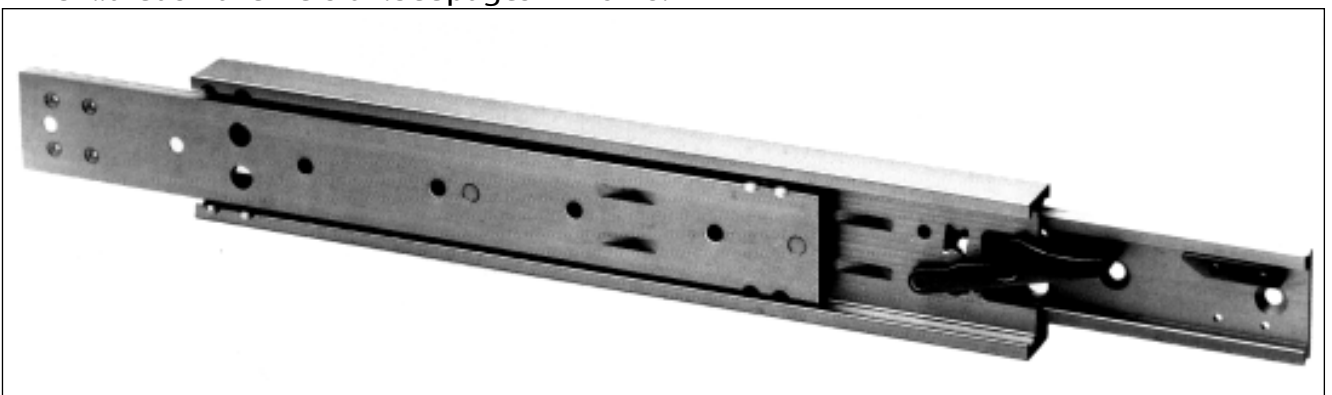

ORDER CODES

LTA51BS - 300

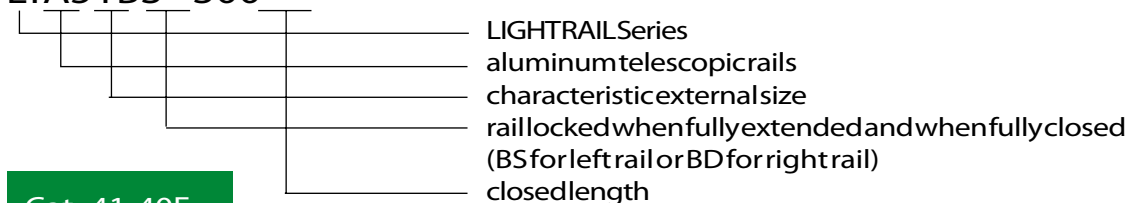



ALUMINUM TELESCOPIC RAILS LTA51ES, LTA51ED Series

The LTA51ES and LTA51ED are a pair of ball bearing rails with an integral latching system which locks the rail when fully extended. The photograph shows the latching lever which automatically engages in studs when the rail is fully extended.

The design is symmetrical and the central "I" shaped beam gives the rail excellent load carrying ability.

A row of ball bearings concealed in nylon cages ensures smooth and easy operation.

Dimensions in mm

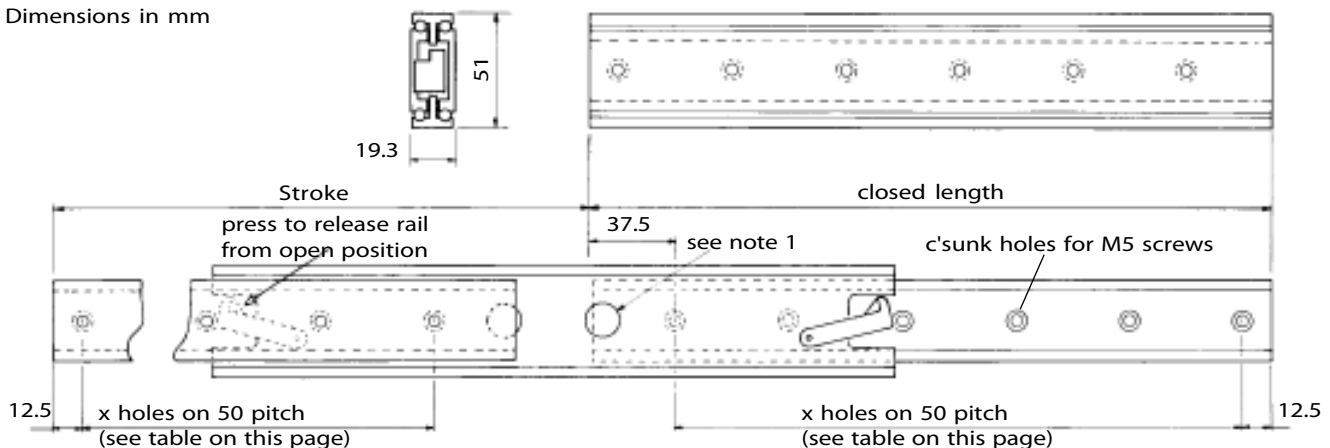

note 1: Ø15 mm holes in center beam allow easy access to fixing holes.

AVAILABILITY

Available in seven lengths as shown below. All incorporate 30 mm over-extension, thus effectively covering depths from around 300 mm to 630 mm.

Special requests can be discussed with our Technical Department.

STANDARD LENGTHS - LTA51ES, LTA51ED Series

Closed length in mm

300 350 400 450 500 550 600

Stroke in mm

330 380 430 480 530 580 630

No. of holes in each beam (x)

6 7 8 9 10 11 12

Cabinet depth must allow for latch space.

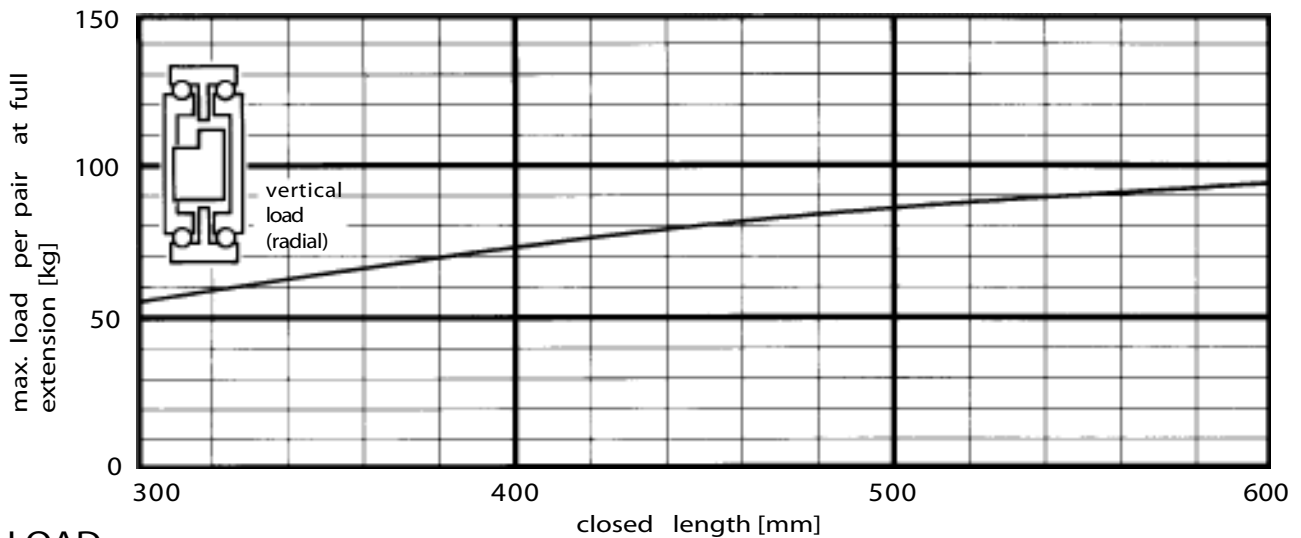

LOAD

This graph assumes a uniformly distributed load acting radially on a pair of rails which are rigidly attached throughout their length to the structure. The maximum load is governed by both the sag of the extended rail and the strength of the other rail components. The result is a slide whose load capacity increases with length over the standard range. The loads indicated are based on a maximum rail deflection of 7 mm and a maximum opening force of 8 kg.

SPECIFICATIONS

- All beams are made from anodized aluminum alloy
- Latch components diecast in zinc alloy
- Ball bearings inside nylon cages allow the sliding movement.
- Maximum operating temperature 70°C.
- Weight 3.4 kg/m per pair.

OPTIONS

- LTA51 are similar but do not incorporate a built in latch. See page 20.
- LTA51BS and LTA51BD are similar but incorporate a built in latch which operates when the rail is fully closed or fully extended. See page 22.
- LTA34 are a smaller version. See pages 14-16-18.

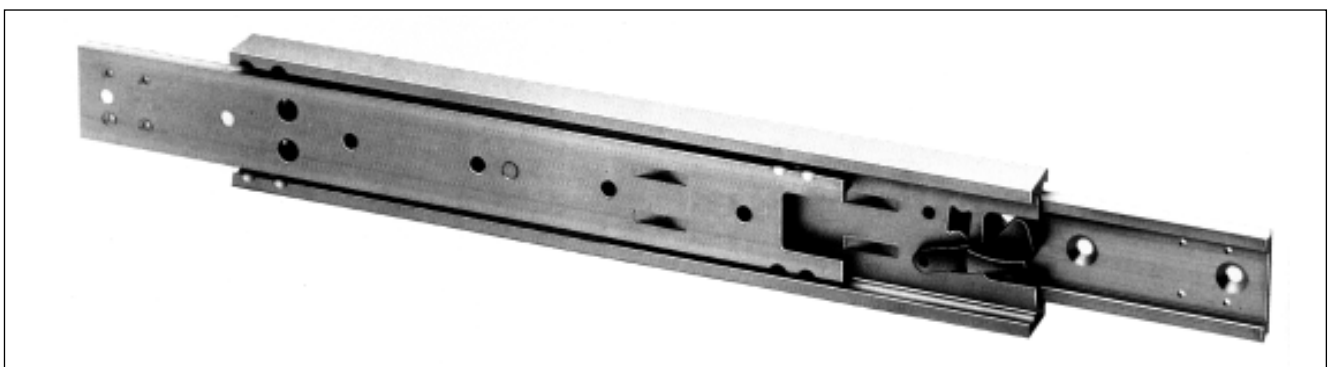

ORDER CODES

LTA51ES - 300

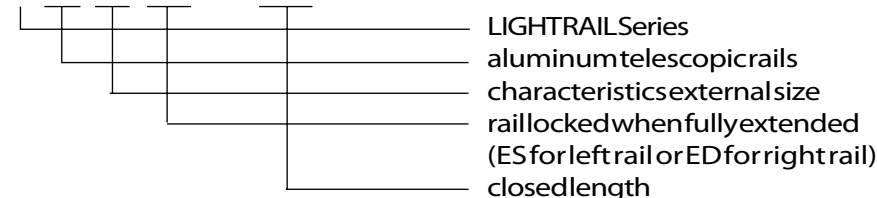



STEEL TELESCOPIC RAILS LTL45 Series

LTL45 slides are a new entry in LIGHTRAIL family products. They are made in three beams, all in folded sheet metal. The slide allows to move the mobile element along the whole length.

Dimensions in mm

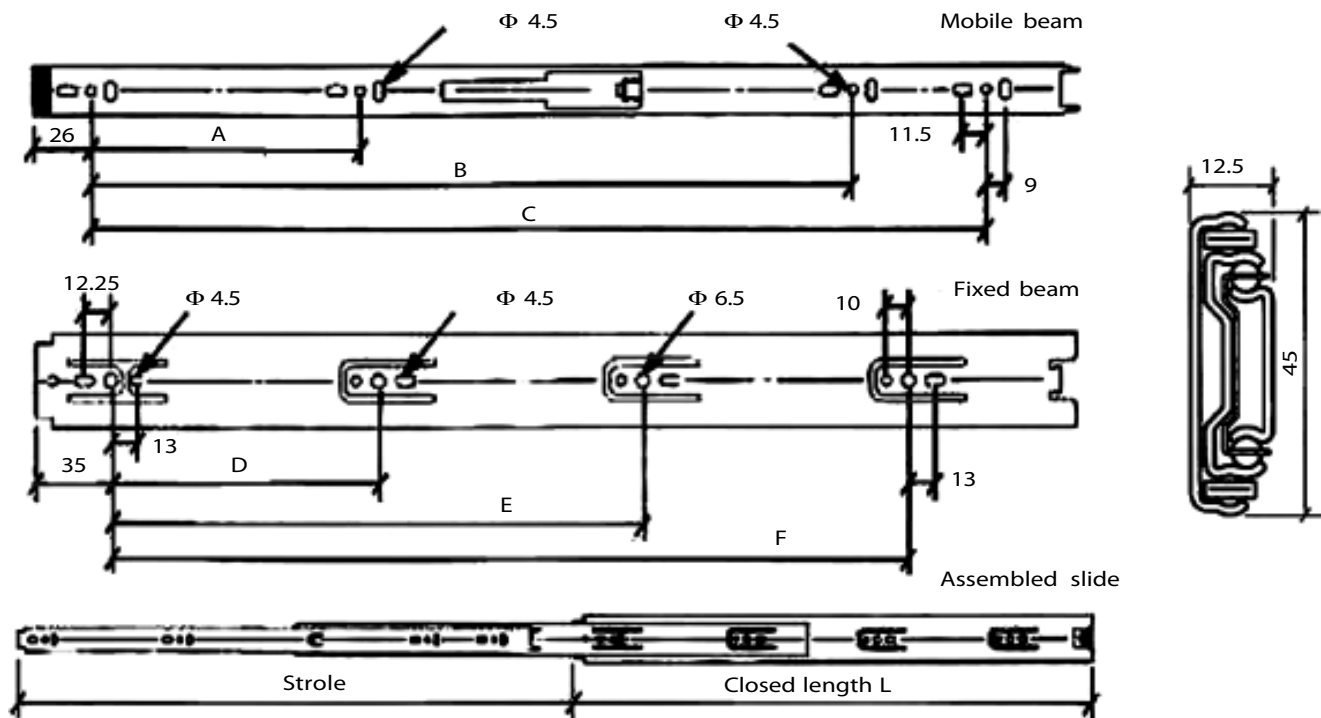

Closed length L (mm)	Stroke (mm)	A (mm)	B (mm)	C (mm)	D (mm)	E (mm)	F (mm)
350	350	-	296	-	128	256	-
400	400	128	320	-	128	288	-
450	450	160	384	-	128	256	352
500	500	160	416	-	128	256	384
550	550	192	-	480	128	288	448
600	600	192	416	512	128	352	480
650	650	192	448	576	128	352	544
700	700	224	480	680	128	352	544

AVAILABILITY

Available in eight lengths as shown above, from 350 to 700 mm. Special requests can be discussed with our Technical Service.

STANDARD LENGTHS - LTL45 Series

Please consult the table above.

**LOAD**

Capacity load: 45 kg

This load must be read as a uniformly distributed load acting radially on a pair of slides 400 mm length which are rigidly attached throughout their length to the structure and to the moving part.

SPECIFICATIONS

All beams are made from zinc plated steel.

Ball bearings allow the sliding movement.

Weight: 5,8 kg/m per pair.

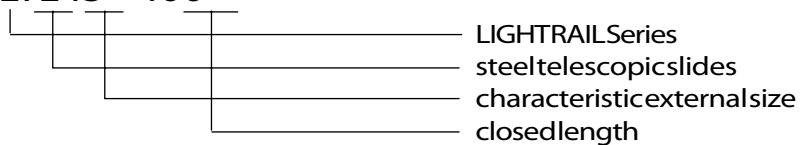
**ORDER CODES****LTL45 - 400**



STEEL TELESCOPIC RAILS LTL56 Series

LTL56 slides are a new entry in LIGHTRAIL family products. They are made in three beams, all in folded sheet metal. The slide allows to move the mobile element along the whole length.

Dimensions in mm

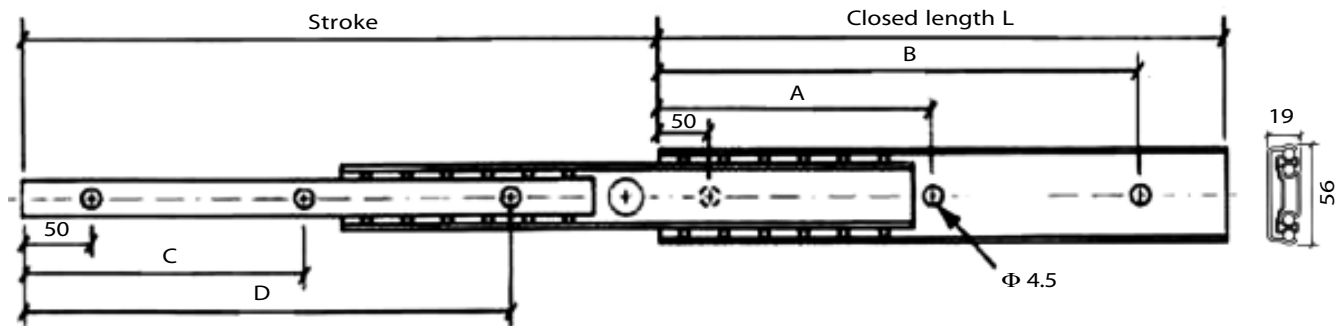

Closed length L (mm)	Stroke (mm)	A (mm)	B (mm)	C (mm)	D (mm)
300	325	178	242	126	222
350	400	210	306	126	254
400	450	210	370	158	318
450	500	242	402	190	350
500	550	242	466	222	414
550	600	274	498	254	446
600	650	306	562	286	510
650	700	338	594	318	574
700	750	370	626	318	606

AVAILABILITY

Available in nine lengths as shown above, from 300 to 700 mm. Special requests can be discussed with our Technical Service.

STANDARD LENGTHS - LTL56 Series

Please consult the table above.



LOAD

Capacity load: 60kg

This load must be read as a uniformly distributed load acting radially on a pair of slides 600mm length which are rigidly attached throughout their length to the structure and to the moving part.

SPECIFICATIONS

All beams are made from zinc plated steel.

Ball bearings allow the sliding movement.

Weight: 3,9 kg/m per pair.



ORDER CODES

LTL56 - 500

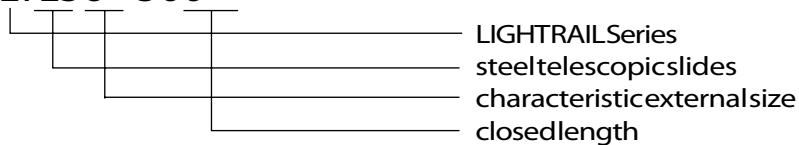



STEEL TELESCOPIC RAILS

LTF68 Series

This four beam telescopic rail has been designed to meet applications which require extension of up to 140% on the product's closed length.

The LTF68 has been specifically developed for sliding assembly applications in which internal components need to be withdrawn completely clear of their enclosures for easy maintenance, service or replenishment, without demounting the equipment.

The extra extension afforded by the LTF68 rail permits clearance at the rear of the chassis for easy and safe access.

Dimensions in mm

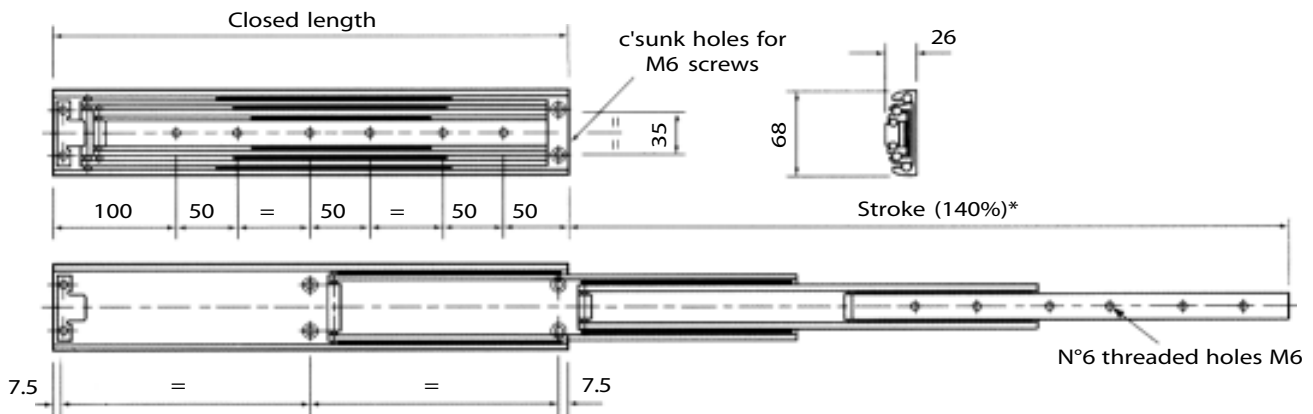

* Note for 100% stroke:
Two central fixing holes in external beam are substituted by a single central hole

AVAILABILITY

The LTF68 rail can be supplied in lengths up to 1000 mm.
Special requests can be discussed with our Technical Department.

STANDARD LENGTHS - LTF68 Series

Closed lengths (in mm)

400 450 500 550 600 650 700 750 800 850 900 950 1000

Stroke (in mm)

560 630 700 770 840 910 980 1050 1120 1190 1260 1330 1400

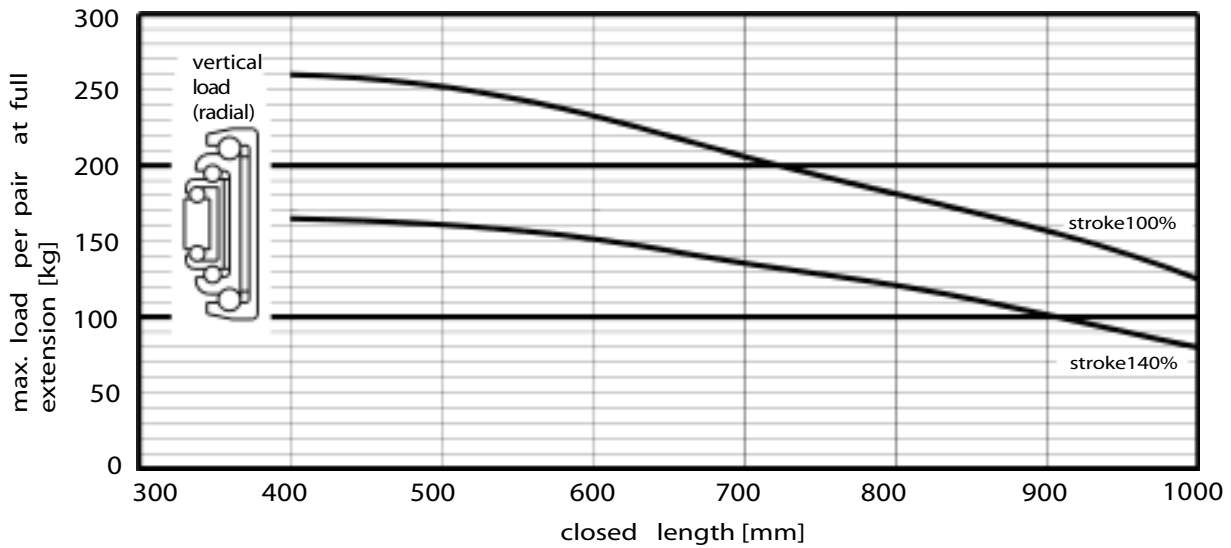

LOAD

The upper graph refers to a pair of rigidly attached rails, mounted radially, carrying a uniformly distributed load.

The two different graphs are for stroke 100% and 140% referring to the closed length. Both graphs refer to rails used under normal conditions.

SPECIFICATIONS

The four beams are mild drawn steel and are yellow zinc plated.

On request we can supply slides without holes (see order codes) on both internal or external beam.



ORDER CODES

LTF68S - 500

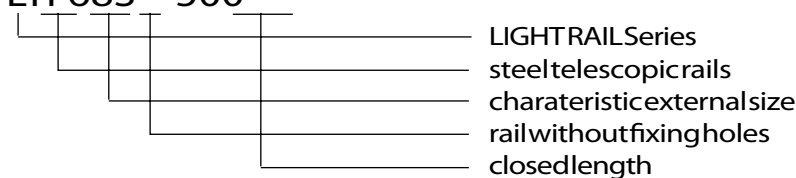



FIXING METHODS

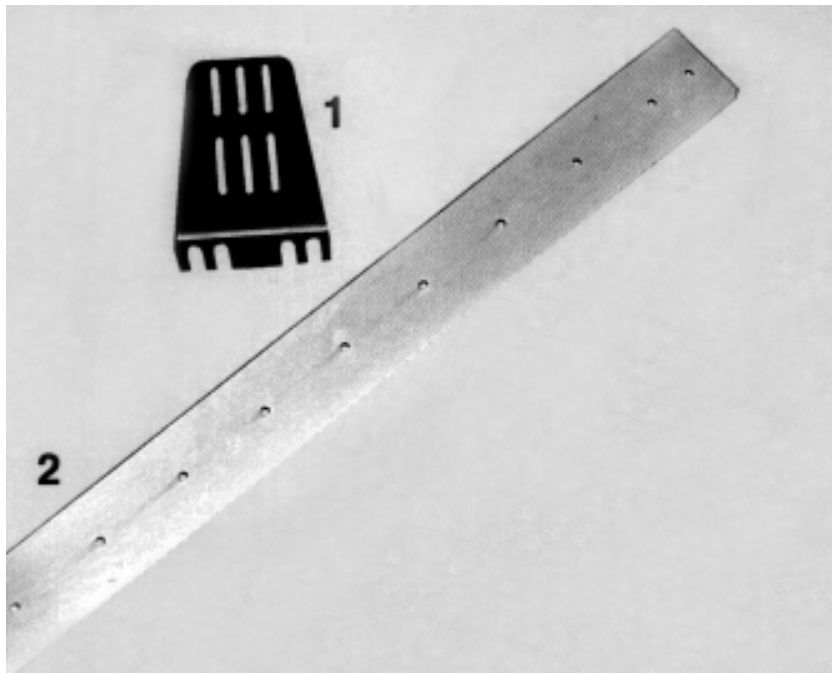

Fixing of the LST33 steel telescopic slides

The ST3 brackets enable LST slides to be quickly fitted into an electronic (19") equipment rack.

The ST1 and ST2 mounting beams used with ST3 brackets, both strengthen the slides and enable short slides to be fitted into a deeper rack.

ST3 brackets

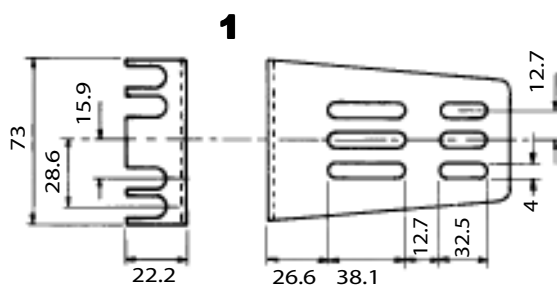

ST1 and ST2 mounting beams

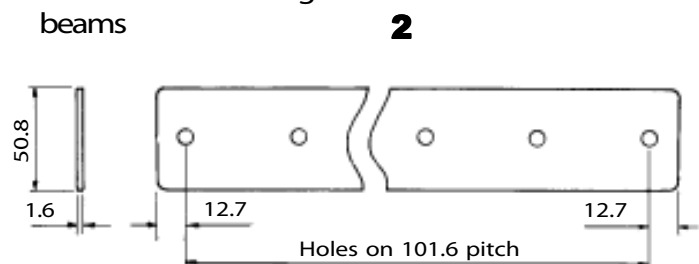

Dimensions in mm

The ST3 brackets are in zinc plated and passivated steel (1.2 mm thick) supplied in sets of four with fixing screws.

ST1 mounting beam length 431,8 mm.
ST2 mounting beam length 558,8 mm.
Zinc plated and passivated steel.

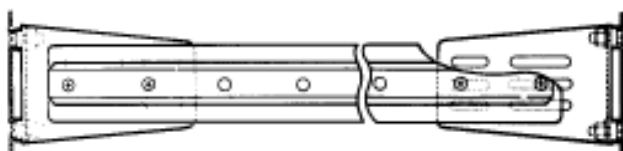

Assembly of slides, mounting beam and brackets.

The bracket and mounting beams illustrated provide equivalent support when the beam cannot be directly fixed to the sides of the framework. The use of beams can usually be omitted for slides up to 501.7 mm long when they are carrying not more than half the recommended maximum load.



More ROLLON product families



COMPACT RAIL:

World's most versatile roller slider system

COMPACT RAIL has all of the characteristics that distinguishes ROLLON's whole product line: originality, innovative designs, compactness, smooth movement, and ease of use. The T+U and K+U rail systems can be mounted on non-machined surfaces and can even compensate for mounting surface parallelism inconsistencies. This flexibility allows the design engineer to focus more time and energy on the application itself and not on the components while saving large amounts of mounting time and, therefore, money. All COMPACT RAIL sliders have radial ball bearing rollers, which provide smooth and fast movement.



TELESCOPIC RAIL:

Industrial telescopic rails

ROLLON's TELESCOPIC RAIL family improves upon all of the characteristics that made our Heavy Duty family of rails well known. Design improvements on existing products and the addition of new ones will allow ROLLON's extended family of telescopic rails to remain the industry leader.

The TELESCOPIC RAIL family offers various types of slides which means that a design engineer can easily find an original solution for each application. All of the products have innovative, problem-solving designs and are built to extend heavy loads out from their mounting structure with little or no deflection.



EASY RAIL:

Strong and easy linear solution

The simple but extremely versatile design of the rails in this family is the characteristic that defines their success. Made from cold-drawn steel with internal, hardened raceways like most of ROLLON's products, these slides are made for 24 hours a day industrial use. With high load and moment capacities, EASY RAIL linear bearings are known for their high quality, affordability, ease of movement, and compactness.



UNILINE: Linear units with roller sliders

A complete family of belt-driven linear actuators designed to run in real-world applications. Based on COMPACTRAIL, these compact units are versatile, fast, and well protected. With designs for every application, UNILINE offers "personalized" actuators with high load capacity, high stiffness and rigidity, and all in a very compact, high quality package. With tee-slots and standard accessories, this family is as modular and versatile as it is innovative.



ECOLINE: Affordable and innovative linear bearings

ECOLINE's products have been designed to fit in applications where quality movement is needed but high prices are not. The patented design offers a well-protected, smooth slide that is easily and quickly mounted. ECOLINE combines the quality associated with all of ROLLON's products with the affordability needed in application sectors like industrial protective panels, vehicle slides, and machine tool doors. ECOLINE is the answer to labor intensive, homemade solutions, cheap bent steel slides, or expensive, overdesigned round or profiled shafting.



CURVILINE: High flexibility curvilinear rails

ROLLON's CURVILINE is the cost effective linear solution for applications with linear movement that isn't always strictly linear.

CURVILINE is a custom solution made according to your application's needs. The system is composed of one or more sliders and a zinc-plated rail. The sliders have multiple radial ball bearings mounted to them providing the movement and carrying the load.

Two versions are available: one with a constant radius, and one with a variable radius which can be composed of both straight and curved sections. Each version has its own specific slider which is designed to uniformly follow the rail without modification to its preload. All sliders have radial ball bearings which are lubricated for life and offer long life due to their hardened raceways. The applications for CURVILINE are varied and allow linear solutions which were up to now impossible. Enclosures for machines, doors for trains and buses, and movements in the packaging and medical fields are just a few of the applications that CURVILINE can facilitate.