



PACIFIC INTERNATIONAL
BEARING SALES, INC.
800.228.8895 • WWW.PACIFICBEARINGSALES.COM

MOTION & CONTROL™
NSK

High Dust-resistant Ball Screws V1 Series



NSK's advanced, high performance seal delivers more than four times longer service life under contaminated environments than existing products.

Patent Pending



For more information about NSK products, please contact: _____



PACIFIC INTERNATIONAL
BEARING SALES, INC.
800.228.8895 • WWW.PACIFICBEARINGSALES.COM



Printed on 100% recycled paper.

With dramatically improved sealing performance, the V1 series delivers outstanding functionality and long operating life under contaminated environments.

A wide range of options enables users to select the ideal choice for specific application needs, from processing machinery to large-sized tables and conveyors.

Applications
Laser cutting machines, Tire buffing machines
Woodworking machines, Chip moulder
Precision transporting equipments, Positioning units, Robots, Welding lines, and others

Features

High dust-resistance

Reduces particle penetration rate to less than 1/15

Specially profiled screw shaft grooves and high performance seals prevent the entry of fine contaminants. Reduces particle penetration rate to less than 1/15 of existing standard products.

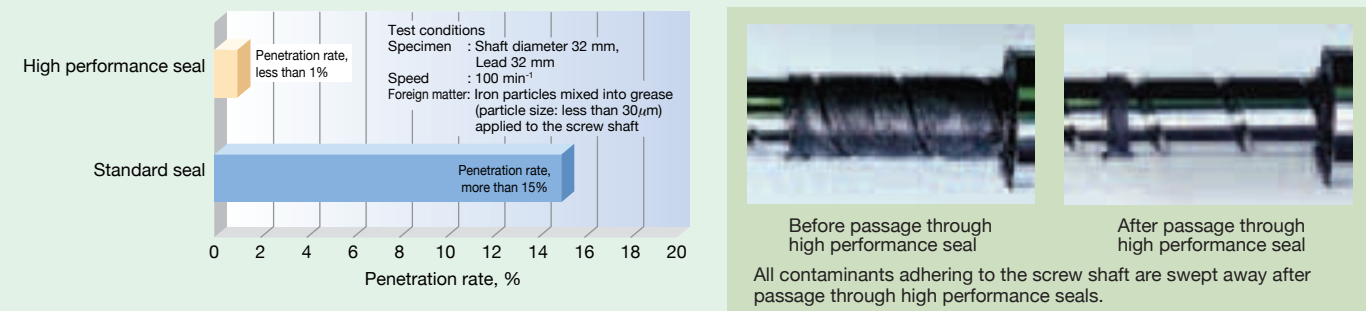
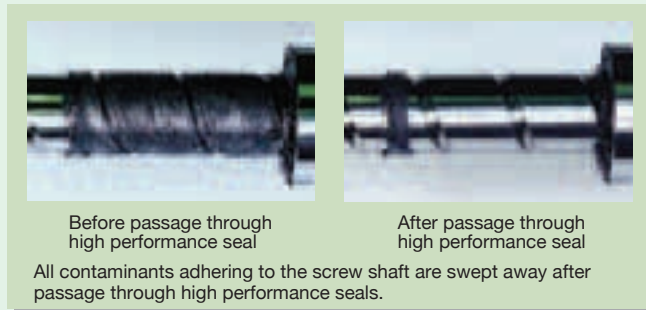

Fig. 1 Particle penetration rate



Contamination before and after particle penetration test

Long life

More than four times longer service life under contaminated environments

High performance seals extend ball screw durability under severely contaminated environments with iron powder. Extreme durability tests under contaminated environments show the durability of the V1 series extends more than four times longer than our existing series with a standard seal.

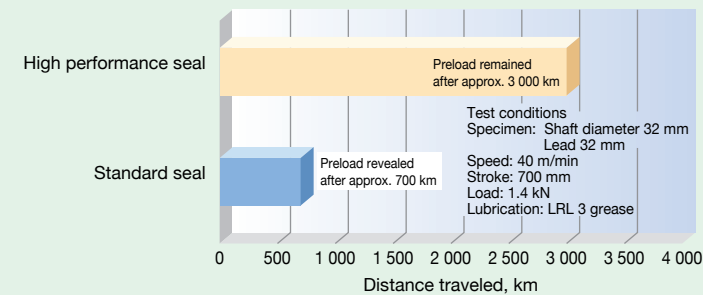

Fig. 2 Extreme durability test results using iron particles

High speed

High-speed operation up to 150 000 d·n

For ultimate smoothness of ball recirculation, the internal ball recirculation method enables high-speed operation at a maximum of d·n 150 000. Large lead specifications allow high-speeds of 150 m/min.

Note: Critical speed due to resonance of the screw shaft should be examined for individual strokes. To determine critical speed, refer to the NSK General Catalog of Precision Machine Components (CAT No. E3161).

Low-noise

Quieter by 6 dB

Reduces noise level by more than 6 dB compared with our conventional tube-type ball screws, thereby providing low-noise and good noise tone features.

Compact size

25% smaller diameter saves space

Ball nut external diameter is up to 25% smaller than our conventional models, making possible compact configurations for low-profile XY tables as well as for other devices and equipment.

Specifications

1. High performance seal

High performance seal (Japan patents: 3646452, 3692203) with special lip that contacts screw shaft cross-section and prevents entry of fine contaminants.

2. NSK K1™ lubrication unit

Incorporates NSK K1™ lubrication unit to sufficiently lubricate the high performance seal lip, reduce friction, and improve durability.

3. Recirculation method

Adopts end deflector recirculation method instead of conventional ball recirculation method using a return tube; deflector mounted inside the nut smoothly scoops up balls in their moving direction.

4. Accuracy

JIS C5 lead accuracy is available as standard. For additional information about accuracy, please contact NSK.

5. Preload and axial play

- Preloading ... Adopts oversized ball preload, suitable for compact devices.
- Axial play ... Axial play can be selected from less than or equal to 0 (code Z), 0.005 mm (code T), or 0.02 mm (code S).

6. Screw shaft design

Ball screw shaft diameter on either shaft end should be less than or equal to root diameter (d_r in Table 1).

7. Protector (optional)

Non-contact metal protector that traces the ball screw grooves and safeguards the seal against high-temperature foreign matter.

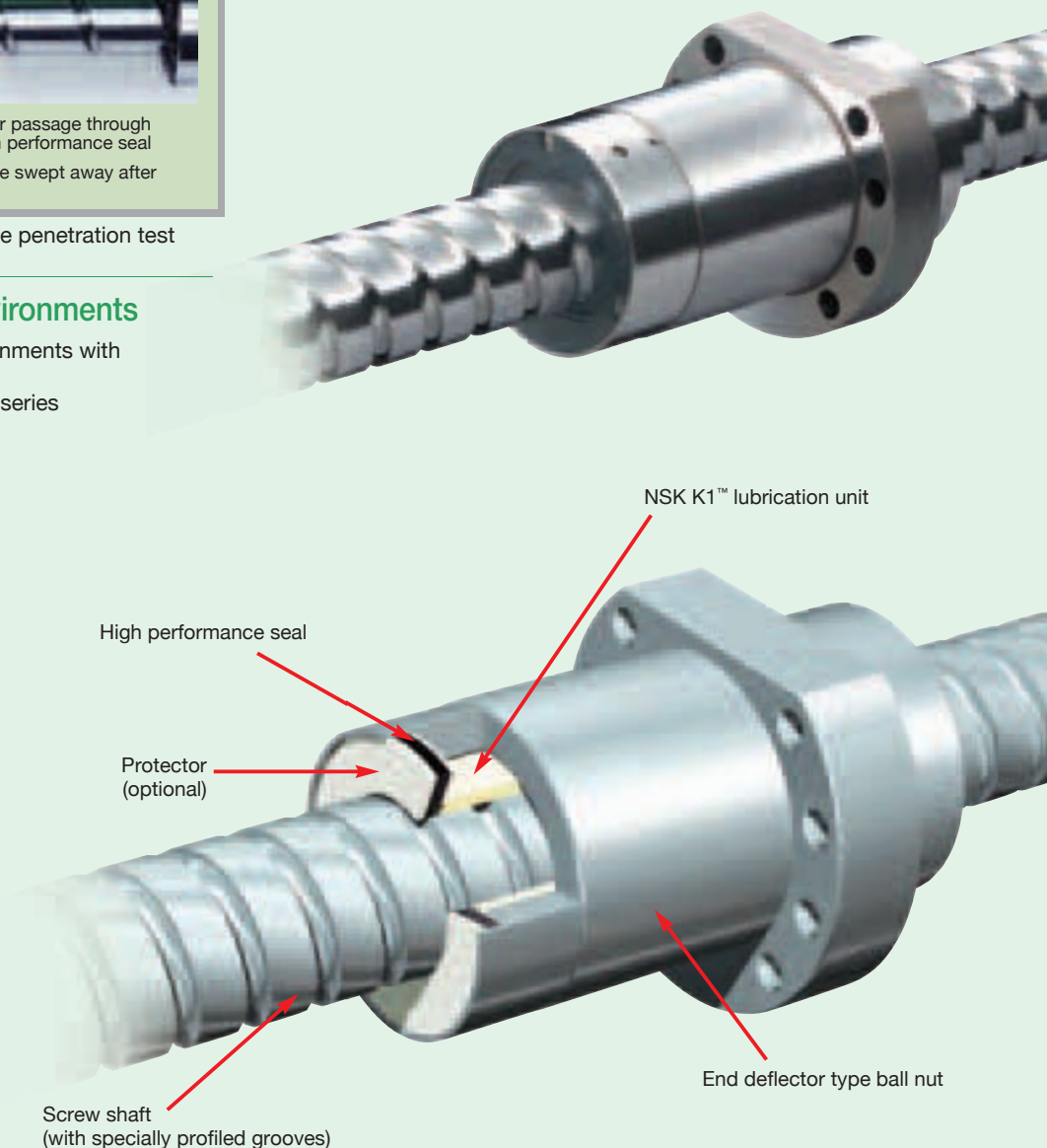

Handling Precautions

Observe the following precautions to maintain the long-term efficiency of these high performance seals:

1. Permissible temperature range ... Maximum operating temperature: 50 °C
Maximum momentary operating temperature: 80 °C
Note: High performance seals may increase torque, which may in turn increase temperature. Please consult with NSK prior to usage under severe service conditions.
2. Chemical precautions ... Never expose the ball screw to grease-removing organic solvents such as hexane or thinner. Never immerse the ball screw in kerosene or rust preventive oils which contain kerosene.

V1 Series Dimensions

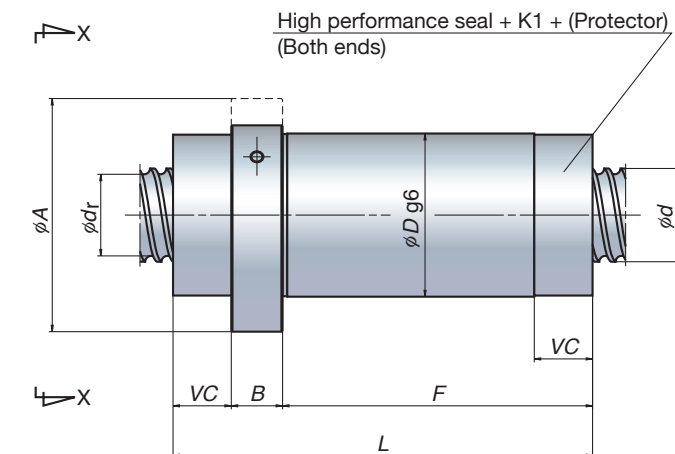
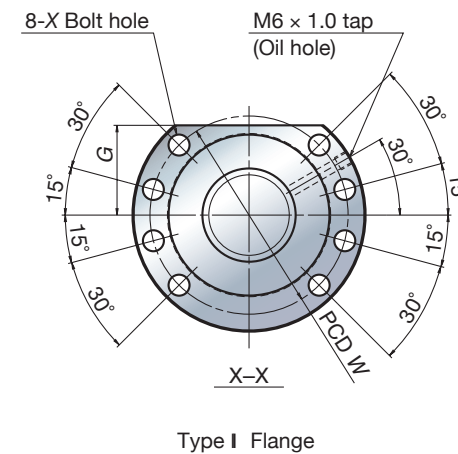
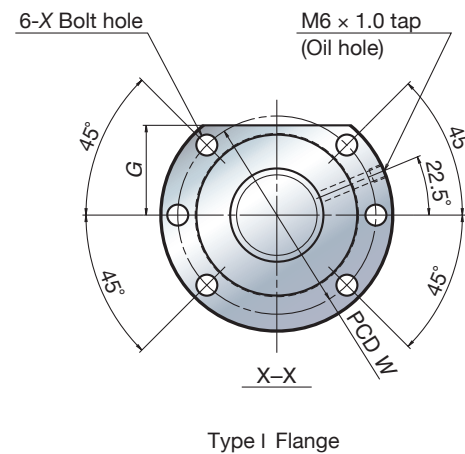
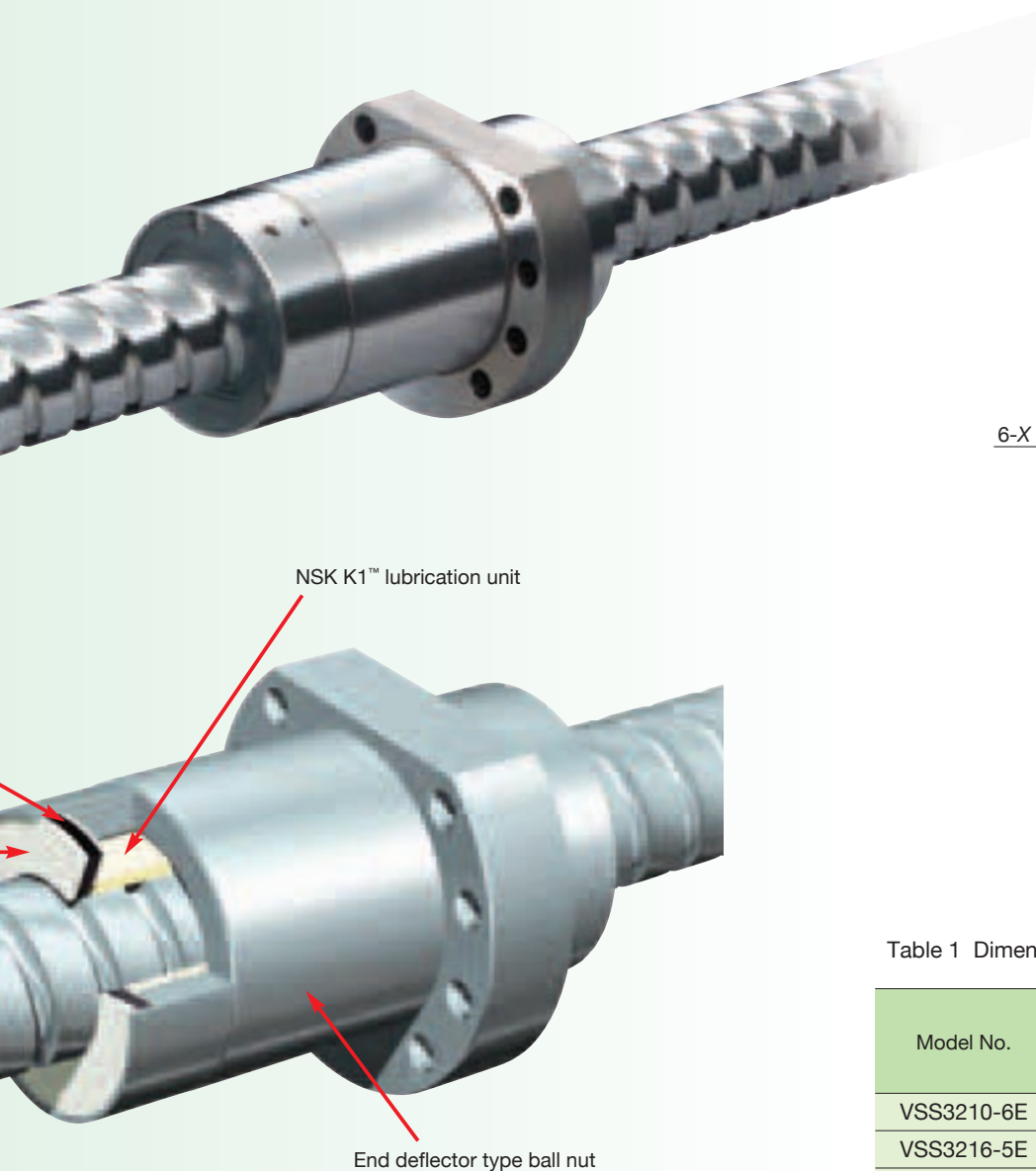

Specification number

Specification numbers may be used as a guide for customers and NSK prior to finalizing specifications. It is used when requesting estimates or inquiring about specifications. Please provide a drawing to specify shaft end profile.

Example: **VSS 32 16 - C5 Z 850 / 1234**

VSS (High dust-resistant ball screws V1 series)
Screw shaft diameter (mm): 32, 40, 50
Lead (mm): 10, 16, 20, 32, 40, 50

Total screw shaft length (mm)
Screw length (mm)
Axial play code (Z, T, S)
Accuracy grade code (C5)

Table 1 Dimensions

Model No.	Screw shaft diameter d (mm)	Lead (mm)	Root diameter d_r (mm)	Effective turns of balls	Basic load rating		Axial rigidity ^{*1} (N/μm)	Nut dimensions (mm)							Maximum shaft length ^{*2} (mm)				
					Dynamic C_a (N)	Static C_{0a} (N)		D	A	L	B	F	G	VC		TYPE	W	X	
VSS3210-6E	32	10	27.2	6	43 300	111 000	682	56	86	132	18	89.5	34	24.5	I	71	M8	2 800	
VSS3216-5E		16		5	36 700	90 800	563												107.5
VSS3220-5E		20		5	36 700	90 800	561												126.5
VSS3232-4E		32		4	25 000	58 300	387												79.5
VSS4040-4E	40	40	34.4	4	33 600	83 900	472	70	100	144	22	94	38.5	27.5	II	85	M8	3 800	
VSS5050-4E	50	50	44.4	4	37 300	105 000	559	82	118	164	22	114.5	46	27.5	II	100	M10	5 000	

*1 Rigidity values in this table are theoretical values derived from elastic deformation between screw grooves and balls when axial load is applied to a ball nut for which preload is set at 1.5% of the basic dynamic load rating (C_a).
*2 Products with axial play may have a partially negative play (preloaded condition) depending on screw length. Refer to the NSK general catalog of Precision Machine Components CAT. No. E3161: "Manufacturing range of effective screw length in combination of accuracy grade and axial play."



For more information about NSK products, please contact: _____



PACIFIC INTERNATIONAL BEARING SALES, INC.
800.228.8895 • WWW.PACIFICBEARINGSALES.COM



Printed on 100% recycled paper.